



GRADING QUESTIONNAIRE & BEST MANAGEMENT PRACTICES

Background: Grading is regulated by Chapter 15 of the Town of Paradise Municipal Code (PMC). Grading is the removal or deposition of earth material by artificial means. Earth material is defined as any rock or natural soil or combination thereof. Grading is generally a combination of excavation (cuts) and placement (fill) of soil. Grading does not include routine farming practices. See PMC §15.02.290. Common examples of grading include construction of driveways, building pads, or site improvements, and restoration or stabilization of hillsides, slopes, or stream banks. A grading permit is required prior to commencing any grading or related work, including preparatory site clearing and soil disturbance, except where exempted from permit requirements by PMC §15.02.290 J103.

Questionnaire: To determine if a project requires a grading permit, please answer all the questions below. If a response to any question is unknown, contact a design professional for assistance and/or consult with the Town of Paradise Development Services staff. **Incorrect or false answers may cause delays processing and/or issuing permits related to the project.**

Questions	Yes	No	Unknown
1. Does the project include excavation which exceeds two feet in vertical depth at its deepest point measured from the original ground surface and which does not create a cut slope greater than four feet in height and steeper than one and one-half horizontal to one vertical and does not exceed fifty (50) cubic yards of material.	<input type="checkbox"/>	<input type="checkbox"/>	<input type="checkbox"/>
2. Does the project have a fill that exceeds one foot in vertical depth and is placed on natural terrain with a slope flatter than five horizontal to one vertical at its deepest point measured from the natural ground surface, or less than three feet in depth, not intended to support structures, which do not exceed fifty cubic yards on any one lot and does not change the existing drainage pattern	<input type="checkbox"/>	<input type="checkbox"/>	<input type="checkbox"/>
3. Does the project have an excavation below finish grade for a basement, footing, retaining wall, swimming pool, or other structure authorized by a valid permit, which excavation will be completely occupied by and retained by the structure authorized by valid building permit.	<input type="checkbox"/>	<input type="checkbox"/>	<input type="checkbox"/>
4. Does the project include a fill above existing grade, which fill will be retained by the exterior wall of a building, a retaining wall, swimming pool or other structure authorized by a valid building permit	<input type="checkbox"/>	<input type="checkbox"/>	<input type="checkbox"/>

Acknowledgment: I, as the applicant, understand that a "Yes" answer to any of the above questions means that a grading permit maybe required for my project and that the grading permit must be issued before any related building permit(s) can be issued. If any answers are "Unknown" to me, I should contact my design professional immediately to determine if a grading permit is required for my project or circumstance. Furthermore, I understand that incorrect or false answers may cause delays processing and/or issuing permits related to my project.

Applicant Printed

Applicant Signature

The Town's Phase II MS4 NPDES General Permit issued by the State Water Board to the Town, requires the Town to develop and maintain a program to assure that sediment and other pollutants from construction activities do not flow into the Town's storm water drainage system and, subsequently, impact local receiving waters. The Town's Permit requires the Town to require the owner of any construction project having soil disturbance to submit an Erosion and Sediment Control Plan (ESCP). The ESCP must identify potential sources of erosion and sedimentation associated with the project and identify the control measures (best management practices or BMPs) used to prevent erosion and control sedimentation within the project. This document lists all the required (Town of Paradise Stormwater Pollution Prevention Program best management practices BMP's)

All construction projects that have soil disturbance and pass through plan check or the Town's permitting process must develop an ESCP. Projects having more than 1 acre of soil disturbance or those projects that are part of a larger common plan may be required to comply with the State Water Board's Construction General Permit (CGP), which requires the development of a Storm Water Pollution Prevention Plan (SWPPP). For these larger projects, the CGP-required SWPPP may be submitted in lieu of the ESCP. For all other projects (small projects) having less than 1 acre of soil disturbance or those that qualify for a waiver or exemption from the CGP, they must submit an ESCP using this worksheet.

Applicant Printed

Name Property Address(es)

Applicant Signature

Assessor's Parcel Number(s)

Date

Building Permit Number(s)



Town of Paradise Stormwater Pollution Prevention Program

Best Management Practices For Small Construction Projects

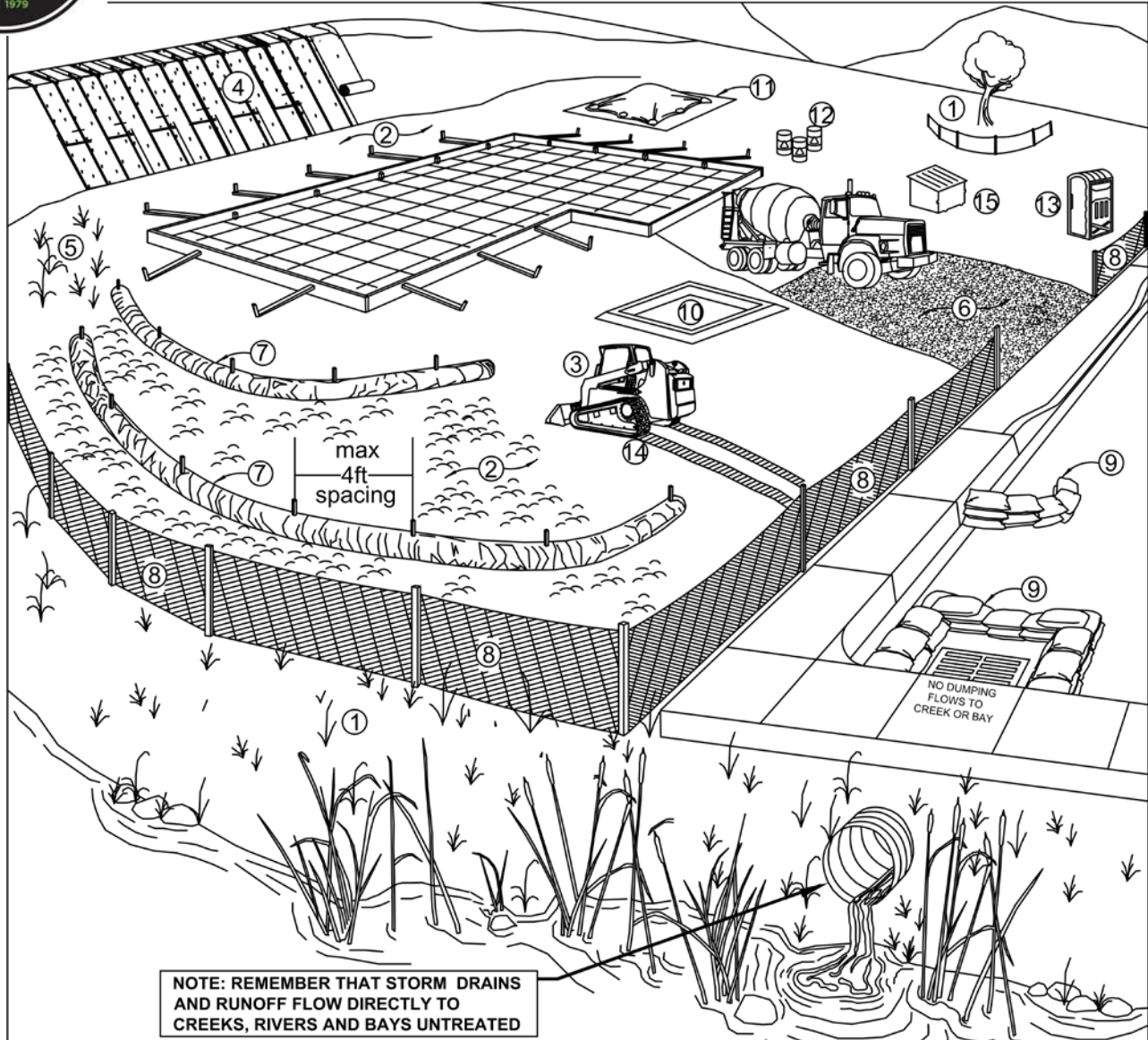

<u>Erosion Controls</u>	<u>Sediment Controls</u>	<u>Good Housekeeping</u>
NS Scheduling	6. Tracking Controls	10. Concrete Washout
1. Preserve Vegetation & Creek SetBacks	7. Fiber Rolls	11. Stockpile Management
2. Soil Cover	8. Silt Fence	12. Hazardous Material Management
3. Soil Preparation/ Roughening	9. Drain Inlet Protection	13. Sanitary Waste Management
4. Erosion Control Blankets	NS Trench Dewatering	14. Equipment and Vehicle Maintenance
5. Revegetation		15. Litter and Waste Management

NS=not shown on graphic

Note: Select an **effective combination of control measures from each category**, Erosion Control, Sediment Control, and Good Housekeeping. Control measures shall be **continually implemented and maintained throughout the project** until activities are complete, disturbed areas are stabilized with permanent erosion controls, and the local agency has signed off on permits that may have been required for the project. **Inspect and maintain the control measures** before and after rain events, and as required by the local agency or state permit.

More detailed information on the BMPs can be found in the related California Stormwater Quality Association (CASQA) and California Department of Transportation (Caltrans) BMP Factsheets. CASQA factsheets are available by subscription in the *California Best Management Practices Handbook Portal: Construction* at <http://www.casqa.org>. Caltrans factsheets are available in the *Construction Site BMP Manual March 2003* at <http://www.dot.ca.gov/hq/construc/stormwater/manuals.htm>.

Control Measure		General Description
Erosion Control Best Management Practices		
N/A	Scheduling	Plan the project and develop a schedule showing each phase of construction. Schedule construction activities to reduce erosion potential, such as scheduling ground disturbing activities during the summer and phasing projects to minimize the amount of area disturbed. <i>For more info see the following factsheets: CASQA: EC-1; or Caltrans: SS-1.</i>
1	Preserve Existing Vegetation and Creek Setbacks	Preserve existing vegetation to the extent possible, especially along creek buffers. Show creek buffers on maps and identify areas to be preserved in the field with temporary fencing. Check with the local Planning and Public Works Departments for specific creek set back requirements. <i>For more info see the following factsheets: CASQA: EC-2; or Caltrans: SS-2.</i>
2	Soil Cover	Cover exposed soil with straw mulch and tackifier (or equivalent). <i>For more info see the following factsheets: CASQA: EC-3, EC-5, EC-6, EC-7, EC-8, EC-14, EC-16; or Caltrans: SS-2, SS-4, SS-5, SS-6, SS-7, SS-8.</i>
3	Soil Preparation/Roughening	Soil preparation is essential to vegetation establishment and BMP installation. It includes soil testing and amendments to promote vegetation growth as well as roughening surface soils by mechanical methods (decompacting, scarifying, stair stepping, etc.). <i>For more info see the following factsheets: CASQA: EC-15.</i>
4	Erosion Control Blankets	Install erosion control blankets (or equivalent) on disturbed sites with 3:1 slopes or steeper. Use wildlife-friendly blankets made of biodegradable natural materials. Avoid using blankets made with plastic netting or fixed aperture netting. See: http://www.coastal.ca.gov/nps/Wildlife-Friendly_Products.pdf . <i>For more info see the following factsheets: CASQA: EC-7; or Caltrans: SS-7.</i>
5	Revegetation	Re-vegetate areas of disturbed soil or vegetation as soon as practical. <i>For more info see the following factsheets: CASQA: EC-4; or Caltrans: SS-4.</i>
Sediment Control Best Management Practices		
6	Tracking Controls	Stabilize site entrance to prevent tracking soil offsite. Inspect streets daily and sweep street as needed. Require vehicles and workers to use stabilized entrance. Place crushed rock 12-inches deep over a geotextile, using angular rock between 4 and 6-in. Make the entrance as long as can be accommodated on the site, ideally long enough for 2 revolutions of the maximum tire size (16-20 feet long for most light trucks). Make the entrance wide enough to accommodate the largest vehicle that will access the site, ideally 10 feet wide with sufficient radii for turning in and out of the site. Rumble pads or rumble racks can be used in lieu of or in conjunction with rock entrances. Wheel washes may be needed where space is limited or where the site entrance and sweeping is not effective. <i>For more info see the following factsheets: CASQA: TC-1; TC-3; or Caltrans: TC-1; TC-3.</i>
7	Fiber Rolls	Use fiber rolls as a perimeter control measure, along contours of slopes, and around soil stockpiles. On slopes space rolls 10 to 20 feet apart (using closer spacing on steeper slopes). Install parallel to contour. If more than one roll is used in a row overlap roll do not abut. J-hook end of roll upslope. Install rolls per either Type 1 (stake rolls into shallow trenches) or Type 2 (stake in front and behind roll and lash with rope). Use wildlife-friendly fiber rolls made of biodegradable natural materials. Avoid using fiber rolls made with plastic netting or fixed aperture netting. See: http://www.coastal.ca.gov/nps/Wildlife-Friendly_Products.pdf . Manufactured linear sediment control or compost socks can be used in lieu of fiber rolls. <i>For more info see the following factsheets: CASQA: SE-5 (Type 1); SE-12, SE-13; or Caltrans: SC-5 (Type 1 and Type 2).</i>
8	Silt Fence	Use silt fence as a perimeter control measure, and around soil stockpiles. Install silt fence along contours. Key silt fence into the soil and stake. Do not use silt fence for concentrated water flows. Install fence at least 3 feet back from the slope to allow for sediment storage. Wire backed fence can be used for extra strength. Avoid installing silt fence on slopes because they are hard to maintain. Manufactured linear sediment control can be used in lieu of silt fences. <i>For more info see the following factsheets: CASQA: SE-1; SE-12; or Caltrans: SC-1.</i>
9	Drain Inlet Protection	Use gravel bags, (or similar product) around drain inlets located both onsite and in gutter as a last line of defense. Bags should be made of a woven fabric resistant to photo-degradation filled with 0.5-1-in washed crushed rock. Do not use sand bags or silt fence fabric for drain inlet protection. <i>For more info see the following factsheets: CASQA: SE-10; or Caltrans: SC-10.</i>
N/A	Trench Dewatering	Follow MCSTOPPP BMPs for trench dewatering. http://www.marincounty.org/depts/pw/divisions/mcstoppp/development/~media/Files/Departments/PW/mcstoppp/development/TrenchingSWReqMCSTOPPPFinal6_09.pdf . <i>For more info see the following factsheets: CASQA: NS-2; or Caltrans: NS-2.</i>
Good Housekeeping Best Management Practices		
10	Concrete Washout	Construct a lined concrete washout site away from storm drains, waterbodies, or other drainages. Ideally, place adjacent to stabilized entrance. Clean as needed and remove at end of project. <i>For more info see the following factsheets: CASQA: WM-8; or Caltrans: WM-8.</i>
11	Stockpile Management	Cover all stockpiles and landscape material and berm properly with fiber rolls or sand bags. Keep behind the site perimeter control and away from waterbodies. <i>For more info see the following factsheets: CASQA: WM-3 or Caltrans: WM-3.</i>
12	Hazardous Material Management	Hazardous materials must be kept in closed containers that are covered and within secondary containment; do not place containers directly on soil. <i>For more info see the following factsheets: CASQA: WM-6; or Caltrans: WM-6.</i>
13	Sanitary Waste Management	Place portable toilets near stabilized site entrance, behind the curb and away from gutters, storm drain inlets, and waterbodies. Tie or stake portable toilets to prevent tipping and equip units with overflow pan/tray (most vendors provide these). <i>For more info see the following factsheets: CASQA: WM-9; or Caltrans: WM-9.</i>
14	Equipment and Vehicle Maintenance	Prevent equipment fluid leaks onto ground by placing drip pans or plastic tarps under equipment. Immediately clean up any spills or drips. <i>For more info see the following factsheets: CASQA: NS-8, NS-9, and NS-10; or Caltrans: NS-8, NS-9, and NS-10.</i>
15	Litter and Waste Management	Designate waste collection areas on site. Use watertight dumpsters and trash cans; inspect for leaks. Cover at the end of each work day and when it is raining or windy. Arrange for regular waste collection. Pick up site litter daily. <i>For more info see the following factsheets: CASQA: WM-5; or Caltrans: WM-5.</i>

Notes:

1. Mats/blankets should be installed vertically downslope
2. Staple blankets sufficiently to ensure that material will maintain direct contact with soil

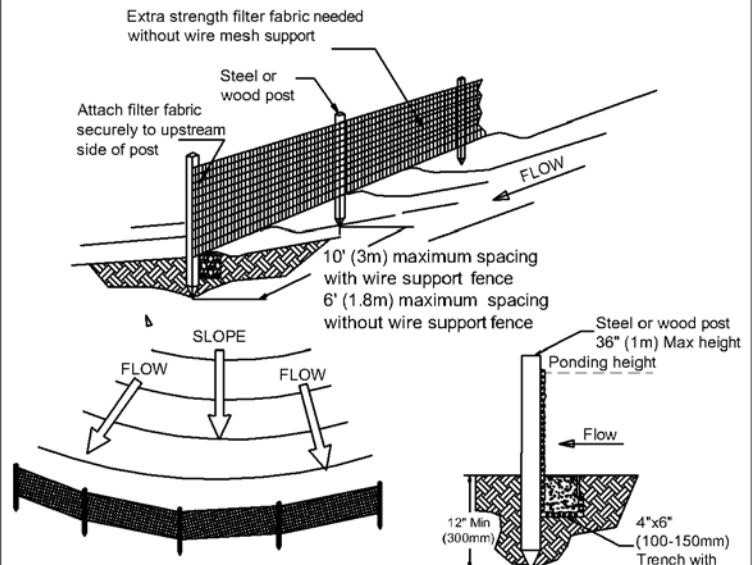
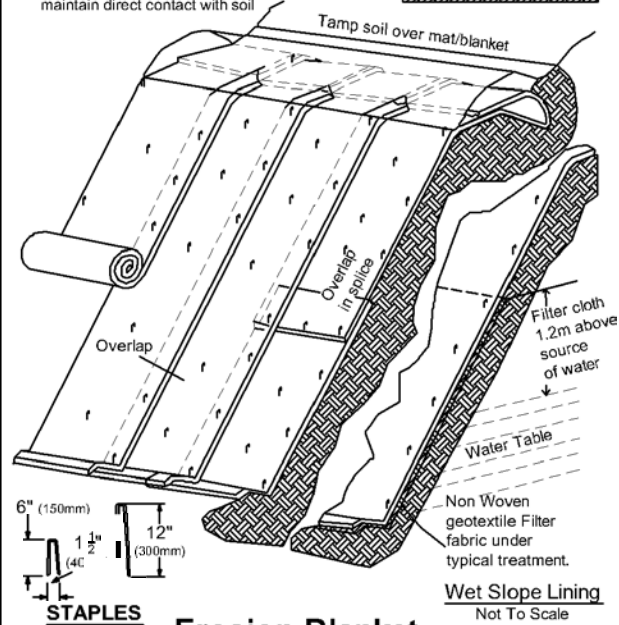

1. Silt fence shall be placed level along slope contours to maximize ponding efficiency with the ends curved uphill to improve ability to retain water.
2. Inspect and repair fence after each storm event and remove sediment when accumulation reaches 1/3 of the barrier height.
3. Removed sediment shall be deposited to an area that will not contribute sediment off-site and can be permanently stabilized

