



# Residential Building Permit

## GETTING STARTED

### This is what the process will look like:

- 1. Debris Removal.** The Consolidated Fire Debris Removal Program has two phases: removal of household hazardous waste and removal of other fire-related debris. To find out more about debris removal, please visit <https://buttecountyrecovers.org/agencies/debris-removal/>.
  - **Tree Removal.** The Town of Paradise and Butte County require private property owners to remove hazard trees on private property that are so fire damaged by the Camp Fire they pose a danger of falling onto a public right-of-way or other public improved facility. **Property owners must enroll in either the Government Tree Program or the Private Tree Program for hazard tree removal.** <https://buttecountyrecovers.org/private-property-tree-removal/>
- 2. Pre-Design Screening.** Take advantage of the Town's free Pre-Design Screening service (PDS). The PDS service provides information and resources to help you submit a complete submittal package and streamline the issuance of your permit. The PDS can help you verify your parcel data, setback and zoning requirements, assessor resources, septic / leach line location more.
  - **Septic System Verification.** (Location of septic system leach lines, approved bedroom count of existing system)
  - **Zoning Verification.** (Make sure your zoning matches the use)
  - **Special Permit Zone.**
- 3. Submit Your Application.** A community development technician will assist you as they verify that all required information is provided for the application intake. They will assist with all permits required during the rebuilding process.

- *An incomplete packet will not be accepted and will require you to come back at a later time with the supplemental information.*

The applicant, or a designee, also needs to contact PG&E and request service at "[Your Project](#)" [service tracking tool \(pge.com\)](#) or [1-877-743-7782](tel:1-877-743-7782). An electronic copy of the site plan is also needed by PG&E to design new or restored service. The Town will require the PG&E service application number prior to issuing a building permit.

- *Have evidence of a **passed post fire septic evaluation or septic repair** permit prior to issuance.*

- 4. Plan Review.** The Town of Paradise's Development Services staff will review your plans for compliance with all Local, State, and Federal codes.
  - Some requirements, including residential fire sprinklers, truss calculations, and solar permits may be listed as a deferred submittal and will be reviewed at a later time. However, we encourage complete submittals instead of deferred submittals as deferred submittals may slow down the permitting process.
  - Our red-line comments process allows our plans examiners to insert conventional or minor comments on the plans to expedite the review process. Some comments may require correction or clarification by the design professional before permits can be issued. Some items will be able to be resolved at the counter or specified on the plan as a deferred submittal.
- 5. Building Permit Issuance.** Building permits will be issued after all required conditions for your project are approved. Smaller projects may be approved over the counter.
- 6. Scheduling Inspections.** Call 530-413-5114 or schedule online <https://citizen.townofparadise.com/CitizenAccess/>. We offer next-day inspection service.





# Residential Building Permit CHECKLIST

**We will rebuild Paradise better and more resilient than before ...  
Below is what you'll need to submit for your building permits:**

## PLAN SUBMITTAL REQUIREMENTS

- 1 copy** of completed Building Permit Application.
- 2 signed sets of complete drawings**, drawn to the current California Building Codes – see the enclosed detailed checklist of drawing and plan requirements. All plans must be legible and a minimum of 24"x36".
- 2 sets of structural calculations** or design per conventional construction provisions.
- 2 sets of energy calculations** (Title 24).
- 2 sets of trusses calculations** (May be deferred). See pg. 8 Calculations
- 1 survey** completed by a land surveyor or civil engineer licensed in land surveying.
- Completed Grading & Best Management Practice Form.
- Copy of **completed** Construction & Demo Recycling Waste Management Plan.
- 2 sets of photovoltaic/solar system plans** (May be deferred).
- 2 sets of residential fire sprinkler plans** (May be deferred).
  - **Flow test performed by PID**
- 1 electronic site plan submitted to PG&E.
- Completed Building Permit Driveway Affidavit

## GENERAL REQUIREMENTS

- All drawings shall be drawn to a common scale. Plan views (floor and elevation) must be drawn to a minimum architectural scale of 1/4"=1'. Site plans drawn to an engineer's scale; 1"=20' is preferred.
- All construction beyond the scope of "Conventional Light-Frame Construction" per the California Building Code (CBC) shall be designed by an architect or engineer licensed by the State of California. Including but not limited to:
  - Retaining walls over 48" high;
  - Foundations with pilings or caissons;
  - Roofs on posts such as carports and patio awnings which are freestanding or which extend more than 6' beyond the building to which they are attached;
  - The wall bracing systems which are not described in the CBC.
- Buildings with more than two stories also require engineered drawings.
- Materials and Construction methods for exterior wildfire exposure, Wildland Urban Interface (WUI) apply.

**Understand and have complied with all plan submittal requirements.**

\_\_\_\_\_  
Signature of Applicant

# REQUIRED DOCUMENTS

## → FULLY DIMENSIONED PLANS – 2 full size sets (24" x 36")

- Title Sheet
- Grading & Drainage Plan
- Site Plan
- Architectural Plans
  - Residential New Construction CALGreen Checklist
- Elevations
- Foundation Plans
- Structural Plans
- Framing Plans
- Roof Plans
- Calculations
- Geotechnical Report (soils report, if applicable)
- Mechanical Details
- Electrical Details
- Plumbing Details
- Septic Evaluation (required if using existing septic system)

## PLAN AND DOCUMENT DETAILED REQUIREMENTS

### → Title Sheet

- Project Address and Assessor Parcel Number.
- Complete Project Description.
- Lot Size.
- Required and Proposed Setbacks.
- Required and Proposed Height and Number of Stories.
- Allowable Density, Proposed Density.
- Required Calculations (existing and proposed square footage, demolished square footage, lot coverage, parking requirements, etc.)
- Zoning Designation and General Plan Land Use Designation.
- Current Applicable Code Edition.
- Existing and Proposed Uses.
- Occupancy Group per California Residential Code CRC Classification (R-3 single-family residential/U storage garage area)
- Owner's Name, Name of Architect/Designer or person preparing the plans, and any other professionals associated with the project.
- Date plans were prepared.
- Reference any applicable case numbers such as conditional use permit, lot mergers, etc.

# REQUIRED DOCUMENTS

## → Grading & Drainage Plan

- Required if grading is in excess of 50 cubic yards (please see Grading Permit & Best Management Practice Form)
  - Grading Permit Questionnaire.
  - Construction BMP's.

## → Site/Plot Plan

- Include all property lines, easements, lot dimensions, streets/alleys with dimensions.
- Using the As-Built on file, accurately draw in the septic system including both the septic tank and leach field.**
- Outline and dimensions of all existing and proposed structures with their uses identified, including accessory structures such as patios, decks, garages, pools, etc.
- Highlight or hash proposed addition(s) or remodel area(s).
- Show all existing and proposed work within the Public right-of-way, including drive apron, drainage improvements, meters, street, pull-boxes, utility poles, etc.
- Required and proposed yard dimensions.
- Vicinity Map showing ½-mile radius street system with project site highlighted.
- North arrow and drawing scale.

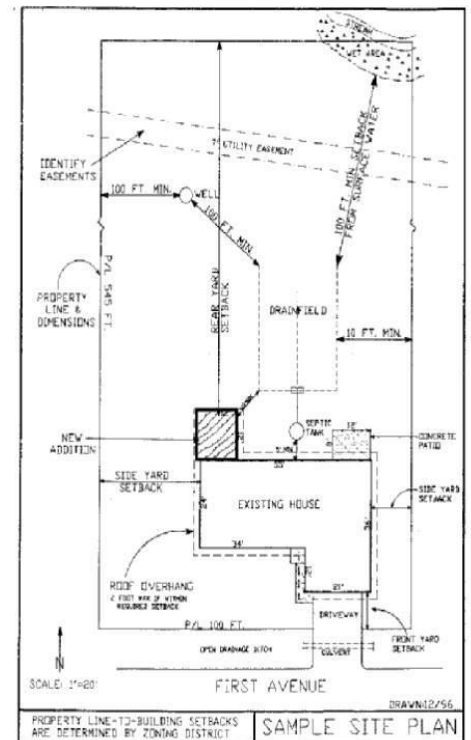

## → Fire Department Site Plan

### Fire Safe Standards

- Emergency access (if house is being moved and new access is required)
- Location of emergency water supply (size and specification of tank/hydrant)
- Submit Fire Sprinkler Plan if required (all new site-built construction shall be provided with Automatic Fire Sprinkler System per California Residential Code).

# REQUIRED DOCUMENTS

## → Architectural Plans

- Provide floor plans for each level of buildings.
- Label the proposed (and existing, if any) use of each room.
- Show location of smoke detectors, carbon monoxide alarms, switches, plugs, and light fixtures.
- Show landings at doors, stairs with rise and run, handrails, guardrails, etc.
- Label overall footprint dimensions and the incremental dimensions where there are changes in the exterior building lines.
- Show the interior layout including walls and other fixed objects.
- Label incremental dimensions showing the size of individual rooms that add up to the overall footprint dimensions.
- Label the dimension and outline of outdoor features (including columns and support posts) immediately adjacent to the building, such as roofed projections (porch covers, patio covers, awnings, canopies) and ground-level paving (landings, steps). Use a single dashed line for rooflines and single solid line for paving edges to distinguish these from other items on the floor plan.
- Label the location and size of exterior openings (doors, windows).
- Show all relevant features and compliance documentation of Title-24 reports.
- Show all relevant features and compliance documentation of the California Green Building Standards Code requirements.
- Show location of Aging in Place Design and Fall Prevention reinforcement blocking [R327].

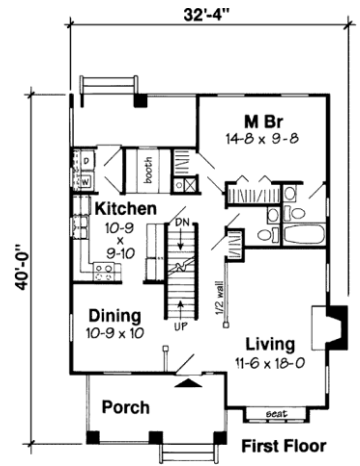

## → Elevation Views

- Provide elevations of all four sides of buildings indicating the different features on the elevations with a key (e.g. 1,2,3,4) that relates to the material table on the same sheet.
- Plans shall include building materials, system and/or assemblies used in the exterior design, and construction of new building or addition to existing building shall comply with the requirements of California State Fire Marshal for Wildland-Urban Interface Code.
- For remodels and additions, distinguish between the existing and new portions of an elevation.
- Label existing, finished and adjacent grades.
- Label the overall height of the building and incremental heights of the floor and ceiling of each level to the top of the building façade from existing grade.
- Provide exterior section elevations of building projection, wings, and other sides not visible on the four elevations provided.
- Label the roofline (in dashed lines) if it is located behind a parapet or other façade that extends above the roofline.
- Show the typical location of roof-mounted equipment.

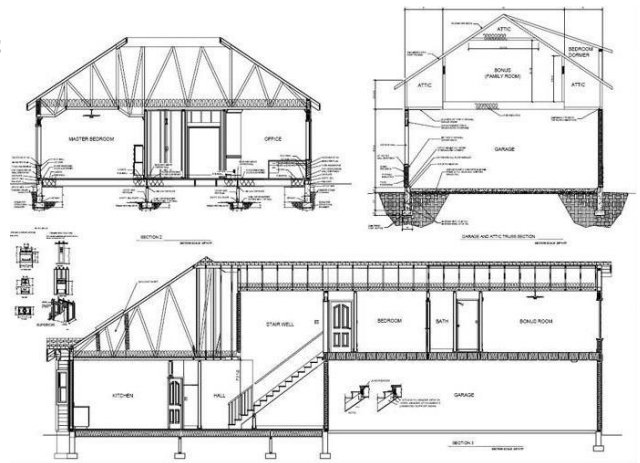

# REQUIRED DOCUMENTS

- Depict compliance with encroachment plane requirements, if applicable.

## → **Foundation Plan**

- Completely dimensioned plan including exterior and interior footing. Label and locate porches, patios, decks, garage, etc.
- All continuous footings with length of each segment in floor plan view.
- Cross-section detail(s) with markers showing where they apply.
- Foundations for interior bearing walls.
- Locations of all pier footings (centers dimensioned in both directions).
- Size and depth of all pier footings.
- Location and size of the embedded portion of all holdowns, anchor bolts, rebar, and straps.
- Post anchor specifications for exterior posts.

### ***For slab floors the following is also required:***

- Footings or 12" footing with two (2) #4 rebar top and bottom under interior Braced Wall Panels with note of how sills will be attached.
- As applicable, note size, number, and location of crawl space vents.

## → **Structural Plans**

- Plans and calculations must be stamped and signed by the licensed professional\*  
**\*Engineering is required for any structure not conforming to the conventional light wood framing and bracing requirements per prescriptive provisions of California Residential Code. All 2 or more story building additions require the stamp of a licensed professional (Architect or Engineer).**
- Identify the use of each room (kitchen, bedroom, family room etc.) with dimensions.
- Provide plans which adequately dimension all braced wall segments and locations for non-engineered plans.
- Identify and dimension engineered shear wall locations and minimum length.
- Justify the amount of bracing provided at each wall line, per wind and seismic requirements of the CRC for non-engineered structures.
- Provide adequate identifications of assumed braced wall lines for conventional bracing, and provide on the plans lateral load resisting gridlines, corresponding to the structural calculations, for engineered structures.
- Show complete detailing of structural connections for lateral and vertical stability, structural specifications, bracing, structural, and construction details.
- Detailed Structural Elements: Foundation, Floor System, Roof Type, Wall.
- Gable End detail / beam elevation changes / rake beam details.
- Structural elements specifications, schedule, sufficient details to indicate code compliance.

# REQUIRED DOCUMENTS

## → Roof Plans

- List roofing material (Class A required).
- Roof Framing: truss anchors and uplifts including permanent bracing.
- Calculations detailing the attic ventilation requirements (Wildland Urban Interface required).
- Reference extent of, and label all framing members, shear or braced walls, wall ties, etc.
- Direction and slope of roof, valleys, hips, skylights, etc.
- Overhangs, eaves, gables, and rakes dimensioned.
- Header size for all openings in bearing walls (may be on floor plan instead).
- Location, size, grade and span of each roof or ceiling beam (or on floor plan).
- Sizes,  $\phi$  to  $\phi$  spacing and spans of rafters and attachment detail.
- Sizes,  $\phi$  to  $\phi$  spacing and spans of ceiling joists and attachment detail.
- Locations and sizes of purlins.
- Location of each purlin support showing where it is supported by a beam or bearing wall.

## → Floor Framing Plan

Identify and dimension all footings, identify framing members and sheathing for floors.

- Size and  $\phi$  to  $\phi$  spacing of girders.
- Size and  $\phi$  to  $\phi$  spacing of joists.
- Dimensions showing spans of girders and joists.
- Size and span of any floor beams.
- Underfloor posts at all point load footings.
- Additional joists or blocking under interior Braced Wall Panels.
- Location and size of underfloor access opening.
- Calculations detailing the underfloor ventilation requirements (Wildland Urban Interface required).

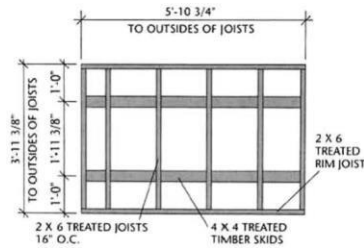

## → Calculations – 2 sets

- “Wet” stamped and signed Structural Calculations.
- Roof truss calculations (may be deferred) **(Provide letter of review by the Registered Design Professional. CBC 2303.4.1.4.1, CRC R802.10.1)**
- Energy Title-24 reports and energy features on plans (registered with a HERS provider)

## → Geotechnical / Soils Report (if required, see Grading Questionnaire)

- Please note that a plan review letter from the geotechnical engineer stating that he/she has reviewed the foundation design and it complies the geotechnical report recommendation.



# REQUIRED DOCUMENTS

## → Mechanical Details

- Location of mechanical equipment.

## → Electrical Details

(Provide electrical service load calculations for dwellings with services 400 amperes or greater, or as determined by the Plans Examiner.)

- Location of electrical meter (existing and proposed)
  - Size of main panel.
  - Surge Protection Device (SPD)
  - Circuit schedule and demand load.
  - Single line diagram.

## → Plumbing Details

- Show all plumbing relevant fixtures and required clearances.
- Include pipe size, material type and fixture unit table.
- Water distribution (required for dwelling units over 5,000 square feet)
- Waste and venting (required for dwelling units over 5,000 square feet)
- Gas distribution (required for projects with a gas demand of over 400,000k btu's)
- Fixture calculations (required for dwelling units over 5,000 square feet)

## → Potential Additional Documents

- Encroachment permit if new driveway encroachment would be required if over 750 sq. ft. above the original sq. ft.
- Identify whether a sidewalk or driveway is necessary.
- Provide plumbing drawings for graywater systems (if applicable).
- Permit for roof mount and/or ground mount photovoltaic systems.
- Permit for retaining walls, pools, or spas.
- A soils compaction letter and plan review letter from a Soils Engineer **may be required**.
- Elevation certificate, prepared by a Civil Engineer, Surveyor, or Architect, for properties located within a Special Permit Zone.
- Permit for well construction or deconstruction (Butte County Environmental Health).
- Permit for septic system installation, replacement, repair, or tank destruction.





# Town of Paradise

Building Resiliency Center  
6295 Skyway, Paradise, CA 95969  
(530) 872-6291 ext 411

## Building Permit Application

Application Date: \_\_\_\_\_ Assessor's Parcel Number: \_\_\_\_\_ BP Number: \_\_\_\_\_  
Project Address: \_\_\_\_\_ City: \_\_\_\_\_ Zip: \_\_\_\_\_

**APPLICANT** Name: \_\_\_\_\_ Phone: \_\_\_\_\_ Cell: \_\_\_\_\_  
Address: \_\_\_\_\_ City: \_\_\_\_\_ State: \_\_\_\_\_ Zip: \_\_\_\_\_  
Email: \_\_\_\_\_ Main Contact:  Applicant  Owner/Tenant  Contractor  Arch/ Eng.

<b>OWNER</b>	<input type="checkbox"/> Representative (Owner's written approval required)	<b>PROFESSIONAL</b>	<input type="checkbox"/> Architect <input type="checkbox"/> Engineer <input type="checkbox"/> Designer
Name: _____		Company Name: _____	
Address: _____		Name: _____ CA Reg. # _____	
City: _____ State: _____		Address: _____	
Zip: _____ Phone: _____		City: _____ State: _____	
Email: _____		Zip: _____ Phone: _____	

**CONTRACTOR** Name: \_\_\_\_\_ Phone: \_\_\_\_\_ License#: \_\_\_\_\_  
Company Name: \_\_\_\_\_ Email: \_\_\_\_\_  
Address: \_\_\_\_\_ City: \_\_\_\_\_ State: \_\_\_\_\_ Zip: \_\_\_\_\_

**PROJECT INFO** Type:  Residential  Commercial/ Industrial  Remodel/ Addition  Demolition  Other  Grading  
Permit For:  Building  Electrical  Plumbing  Mechanical  Re-roof  PV/ Solar  Water Heater  
 Patio Cover/ Deck  Swimming Pool/Spa  Addendum  MH/ Commercial Coach  T.I.  Co-location  Other \_\_\_\_\_

Description of Work: \_\_\_\_\_  
\_\_\_\_\_

Proposed Use: \_\_\_\_\_ Existing Use: \_\_\_\_\_  
Construction Valuation Cost: \_\_\_\_\_ Occupancy Group(s): \_\_\_\_\_  
Zoning District: \_\_\_\_\_ Type of Construction: \_\_\_\_\_ Square Footage: \_\_\_\_\_

### PERMITTEE DECLARATION

I hereby declare under penalty of perjury that the foregoing statements and the attached plan(s) are true, accurate, complete, and correct to the best of my knowledge and belief.

Applicant Signature: \_\_\_\_\_ Date: \_\_\_\_\_





## IMPORTANT NOTICE TO OWNER-BUILDERS

Dear Property Owner:

An application for a building permit has been submitted in your name listing yourself as the builder of the property improvements specified in the Town of Paradise, Butte County, California at:

Property Address: \_\_\_\_\_

Assessor Parcel No. (APN): \_\_\_\_\_ - \_\_\_\_\_ - \_\_\_\_\_ (Owner must be shown on Assessor records)

We are providing you with an Owner-Builder Acknowledge and Information Verification Form to make you aware of your responsibilities and possible risk you may incur by having this permit issued in your name as the Owner-Builder. **We will not issue a building permit until you have read, initialed your understanding of each provision, signed, and returned this form to us at our official address indicated.** An agent of the owner cannot execute this notice unless you, the property owner, obtain the prior approval of the permitting authority.

### **OWNER'S ACKNOWLEDGMENT AND VERIFICATION ON INFORMATION**

*DIRECTIONS: Read and initial each statement below to signify you understand or verify this information.*

\_\_\_\_\_ 1. I understand a frequent practice of unlicensed persons is to have the property owner obtain an "Owner-Builder" building permit that erroneously implies that the property owner is providing his/her own labor and material personally. I, as Owner-Builder, may be held liable and subject to serious financial risk for any injuries sustained by an unlicensed person and his/her employees while working on my property. My homeowner's insurance may not provide coverage for those injuries. I am willfully acting as an Owner-Builder and am aware of the limits of my insurance coverage for injuries to workers on my property.

\_\_\_\_\_ 2. I understand building permits are not required to be signed by property owners unless they are *responsible* for the construction and are not hiring a licensed Contractor to assume this responsibility.

\_\_\_\_\_ 3. I understand as an "Owner-Builder" I am the responsible party of record on the permit. I understand that I may protect myself from potential financial risk by hiring a licensed Contractor and having the permit filed in his/her name instead of my own.

\_\_\_\_\_ 4. I understand Contractors are required by law to be licensed and bonded in California and to list their license numbers on permits and contracts.

\_\_\_\_\_ 5. I understand if I employ or otherwise engage any persons, other than California licensed Contractors, and the total value of my construction is at least five hundred dollars (\$500), including labor and materials, I may be considered an "employer" under state and federal law.

\_\_\_\_\_6. I understand if I am considered an “employer” under state and federal law, I must register with the state and federal government, withhold payroll taxes, provide workers’ compensation disability insurance, and contribute to unemployment compensation for each “employee”. I also understand my failure to abide by these laws may subject me to serious financial risk.

\_\_\_\_\_7. I understand under California Contractors’ State License Law, an Owner-Builder who builds single-family residential structures cannot legally build them with the intent to offer them for sale, unless *all* work is performed by licensed subcontractors and the number of structures does not exceed four within any calendar year, or all of the work is performed under contract with a licensed general building Contractor.

\_\_\_\_\_8. I understand as an Owner-Builder if I sell the property for which this permit is issued, I may be held liable for any financial or personal injuries sustained by any subsequent owner(s) that result from any latent construction defects in the workmanship or materials.

\_\_\_\_\_9. I understand I may obtain more information regarding my obligations as an “employer” from the Internal Revenue Service, the United States Small Business Administration, the California Department of Benefit Payments, and the California Division of Industrial Accidents. I also understand I may contact the California Contractors’ State License Board (CSLB) at 1-800-321-2752 or [www.cslb.ca.gov](http://www.cslb.ca.gov) for more information about licensed contractors.

\_\_\_\_\_10. I am aware of and consent to an Owner-Builder building permit applied for in my name, and understand that I am the party legally and financially responsible for proposed construction activity at the following address: \_\_\_\_\_, Assessor Parcel No: \_\_\_\_\_

\_\_\_\_\_11. I agree that, as the party legally and financially responsible for this proposed construction, activity, I will abide by all applicable laws and requirements that govern Owner-Builder as well as employers.

\_\_\_\_\_12. I agree to notify the issuer of this form immediately of any additions, deletions, or changes to any of the information I have provided on this form. Licensed contractors are regulated by laws designed to protect the public. If you contract with someone who does not have a license, the Contractors’ State License Board may be unable to assist you with any financial loss you may sustain as a result of a complaint. Your only remedy against unlicensed Contractors may be in civil court. It is also important for you to understand that if an unlicensed Contractor or employee of that individual or firm is injured while working on your property, you may be held liable for damages. If you obtain a permit as Owner-Builder and wish to hire Contractors, you will be responsible for verifying whether or not those Contractors are properly licensed and the status of their workers’ compensation insurance coverage.

**Before a building permit can be issued, this form must be completed and signed by the property owner and return to the agency responsible for issuing the permit. Note: A copy of the property owner’s driver’s license, form notarization, or other verification acceptable to the agency is required to be presented when the permit is issued to verify the property owner’s signature.**

Signature of Property Owner: \_\_\_\_\_ Date: \_\_\_\_\_

*Note: The following Authorization Form is required to be completed by the property owner only when designating an agent of the property owner to apply for a construction permit for the Owner-Builder.*

## **AUTHORIZATION OF AGENT TO ACT ON PROPERTY OWNER'S BEHALF**

Excluding the Notice to Property Owner, the execution of which I understand is my personal responsibility, I hereby authorize the following person(s) to act as my agent(s) to apply for, sign, and file the documents necessary to obtain an Owner-Builder Permit for my project.

Scope of Construction Project/Description of Work: \_\_\_\_\_

Project Location/Address: \_\_\_\_\_

Name of Authorized Agent: \_\_\_\_\_ Phone: \_\_\_\_\_

Address of Authorized Agent: \_\_\_\_\_

I declare under penalty of perjury that I am the property owner for the address listed above and I personally filled out the above information and certify its accuracy. *Note: A copy of the owner's driver's license, form notarization, or other verification acceptable to the agency is required to be presented when the permit is issued to verify the property owner's signature.*

Signature of Property Owner: \_\_\_\_\_ Date: \_\_\_\_\_

---

\*Acceptable Verification of Property Owner Signature for the Town of Paradise:

**In person:**

Present original State issued Driver's License or State issued Identification Card

**Agent for Owner:**

Copy of a valid State issued Driver's License or State issued Identification Card

Present notarization of signatures for both 1.) Owner's Acknowledgment and Verification of Information and 2.) Authorization of Agent to Act on Property Owner's Behalf

\_\_\_\_\_  
Staff Signature

\_\_\_\_\_  
Date







**TOWN OF PARADISE**  
**ONSITE WASTEWATER MANAGEMENT ZONE APPLICATION**  
 PHONE: (530) 872-6291 ~ FAX (530) 872-6201



OWNER'S NAME \_\_\_\_\_

ASSESSORS PARCEL: \_\_\_\_\_

OWNER ADDRESS: \_\_\_\_\_

CITY, STATE, ZIP \_\_\_\_\_

APPLICANT'S NAME: \_\_\_\_\_

APPLICANT'S PHONE NO: \_\_\_\_\_

APPLICANT'S ADDRESS: \_\_\_\_\_

APPLICANT'S EMAIL: \_\_\_\_\_

CONSTRUCTION SITE ADDRESS: \_\_\_\_\_

DESIGN ENGINEER: \_\_\_\_\_

**APPLICATION TYPE:**

- |   |   |  |
|---|---|--|
| <input type="checkbox"/> New Construction   | <input type="checkbox"/> Graywater      | <input type="checkbox"/> Extension Request           |
| <input type="checkbox"/> Repair/Construction  | <input type="checkbox"/> Septic Tank    | <input type="checkbox"/> Absorption Field            |
| <input type="checkbox"/> Upgrade/Alteration   | <input type="checkbox"/> Abandonment    | <input type="checkbox"/> Land Use Review             |
| <input type="checkbox"/> Minor Repair (tees, risers, lids, floats, building sewer and etc.) _____ | <input type="checkbox"/> Permit Renewal | <input type="checkbox"/> Building Clearance          |
|   |   | <input type="checkbox"/> Land Division w/application |

System Proposal:

Tank Size: \_\_\_\_\_ gal      Absorption Field: \_\_\_\_\_ ft.      Rock Under Pipe: \_\_\_\_\_ in  
 Circle one: Concrete or Fiberglass or plastic      Pump Type \_\_\_\_\_      Pump Size \_\_\_\_\_

Comments: \_\_\_\_\_

**TYPE OF STRUCTURE SERVED BY PROPOSED SYSTEM:**

<input type="checkbox"/> Single Family Residence; No of Bedrooms: _____	Water Supply:
<input type="checkbox"/> Mobile Home Park; No of units served by System: _____	<input type="checkbox"/> Community
<input type="checkbox"/> Commercial; Type of Occupancy: _____	<input type="checkbox"/> Well

**PLOT PLAN REQUIREMENTS: Indicate all of the following:**

- Plot plan must be drawn to a 1" = 20' Scale. Provide all dimensions to setbacks.
- Property lines, required setbacks, easements, all existing and proposed structures, and location of septic system (existing and proposed). Provide North Arrow.
- Location of large trees, rock outcrops, escarpments and cutbanks.
- Location of any well, spring, drainage way, creek or pond located within 200 feet of the proposed septic system on proposed or adjacent parcels.
- Slope orientation and degree of slope.
- All utilities, i.e. water mains and service lines, gas lines, electric service lines, etc.
- Proposed septic system and, if required, septic system repair area(s).
- Trench section detail, type and location of distribution boxes and section detail of such proposed distribution, i.e. equal serial, step down.
- Floor plan of proposed structure and all appurtenant structures (commercial, new construction and building clearance).

\_\_\_\_\_  
**SIGNATURE OF APPLICANT**

\_\_\_\_\_  
**DATE**





# GRADING QUESTIONNAIRE & BEST MANAGEMENT PRACTICES

**Background:** Grading is regulated by Chapter 15 of the Town of Paradise Municipal Code (PMC). Grading is the removal or deposition of earth material by artificial means. Earth material is defined as any rock or natural soil or combination thereof. Grading is generally a combination of excavation (cuts) and placement (fill) of soil. Grading does not include routine farming practices. See PMC §15.02.290. Common examples of grading include construction of driveways, building pads, or site improvements, and restoration or stabilization of hillsides, slopes, or stream banks. A grading permit is required prior to commencing any grading or related work, including preparatory site clearing and soil disturbance, except where exempted from permit requirements by PMC §15.02.290 J103.

**Questionnaire:** To determine if a project requires a grading permit, please answer all the questions below. If a response to any question is unknown, contact a design professional for assistance and/or consult with the Town of Paradise Development Services staff. **Incorrect or false answers may cause delays processing and/or issuing permits related to the project.**

Questions	Yes	No	Unknown
1. Does the project include excavation which exceeds two feet in vertical depth at its deepest point measured from the original ground surface and which does not create a cut slope greater than four feet in height and steeper than one and one-half horizontal to one vertical and does not exceed fifty (50) cubic yards of material.	<input type="checkbox"/>	<input type="checkbox"/>	<input type="checkbox"/>
2. Does the project have a fill that exceeds one foot in vertical depth and is placed on natural terrain with a slope flatter than five horizontal to one vertical at its deepest point measured from the natural ground surface, or less than three feet in depth, not intended to support structures, which do not exceed fifty cubic yards on any one lot and does not change the existing drainage pattern	<input type="checkbox"/>	<input type="checkbox"/>	<input type="checkbox"/>
3. Does the project have an excavation below finish grade for a basement, footing, retaining wall, swimming pool, or other structure authorized by a valid permit, which excavation will be completely occupied by and retained by the structure authorized by valid building permit.	<input type="checkbox"/>	<input type="checkbox"/>	<input type="checkbox"/>
4. Does the project include a fill above existing grade, which fill will be retained by the exterior wall of a building, a retaining wall, swimming pool or other structure authorized by a valid building permit	<input type="checkbox"/>	<input type="checkbox"/>	<input type="checkbox"/>

**Acknowledgment:** I, as the applicant, understand that a "Yes" answer to any of the above questions means that a grading permit maybe required for my project and that the grading permit must be issued before any related building permit(s) can be issued. If any answers are "Unknown" to me, I should contact my design professional immediately to determine if a grading permit is required for my project or circumstance. Furthermore, I understand that incorrect or false answers may cause delays processing and/or issuing permits related to my project.

\_\_\_\_\_  
Applicant Printed

\_\_\_\_\_  
Applicant Signature

The Town's Phase II MS4 NPDES General Permit issued by the State Water Board to the Town, requires the Town to develop and maintain a program to assure that sediment and other pollutants from construction activities do not flow into the Town's storm water drainage system and, subsequently, impact local receiving waters. The Town's Permit requires the Town to require the owner of any construction project having soil disturbance to submit an Erosion and Sediment Control Plan (ESCP). The ESCP must identify potential sources of erosion and sedimentation associated with the project and identify the control measures (best management practices or BMPs) used to prevent erosion and control sedimentation within the project. This document lists all the required (Town of Paradise Stormwater Pollution Prevention Program best management practices BMP's)

All construction projects that have soil disturbance and pass through plan check or the Town's permitting process must develop an ESCP. Projects having more than 1 acre of soil disturbance or those projects that are part of a larger common plan may be required to comply with the State Water Board's Construction General Permit (CGP), which requires the development of a Storm Water Pollution Prevention Plan (SWPPP). For these larger projects, the CGP-required SWPPP may be submitted in lieu of the ESCP. For all other projects (small projects) having less than 1 acre of soil disturbance or those that qualify for a waiver or exemption from the CGP, they must submit an ESCP using this worksheet.

\_\_\_\_\_  
Applicant Printed

\_\_\_\_\_  
Name Property Address(es)

\_\_\_\_\_  
Applicant Signature

\_\_\_\_\_  
Assessor's Parcel Number(s)

\_\_\_\_\_  
Date

\_\_\_\_\_  
Building Permit Number(s)



# Town of Paradise Stormwater Pollution Prevention Program

## Best Management Practices For Small Construction Projects

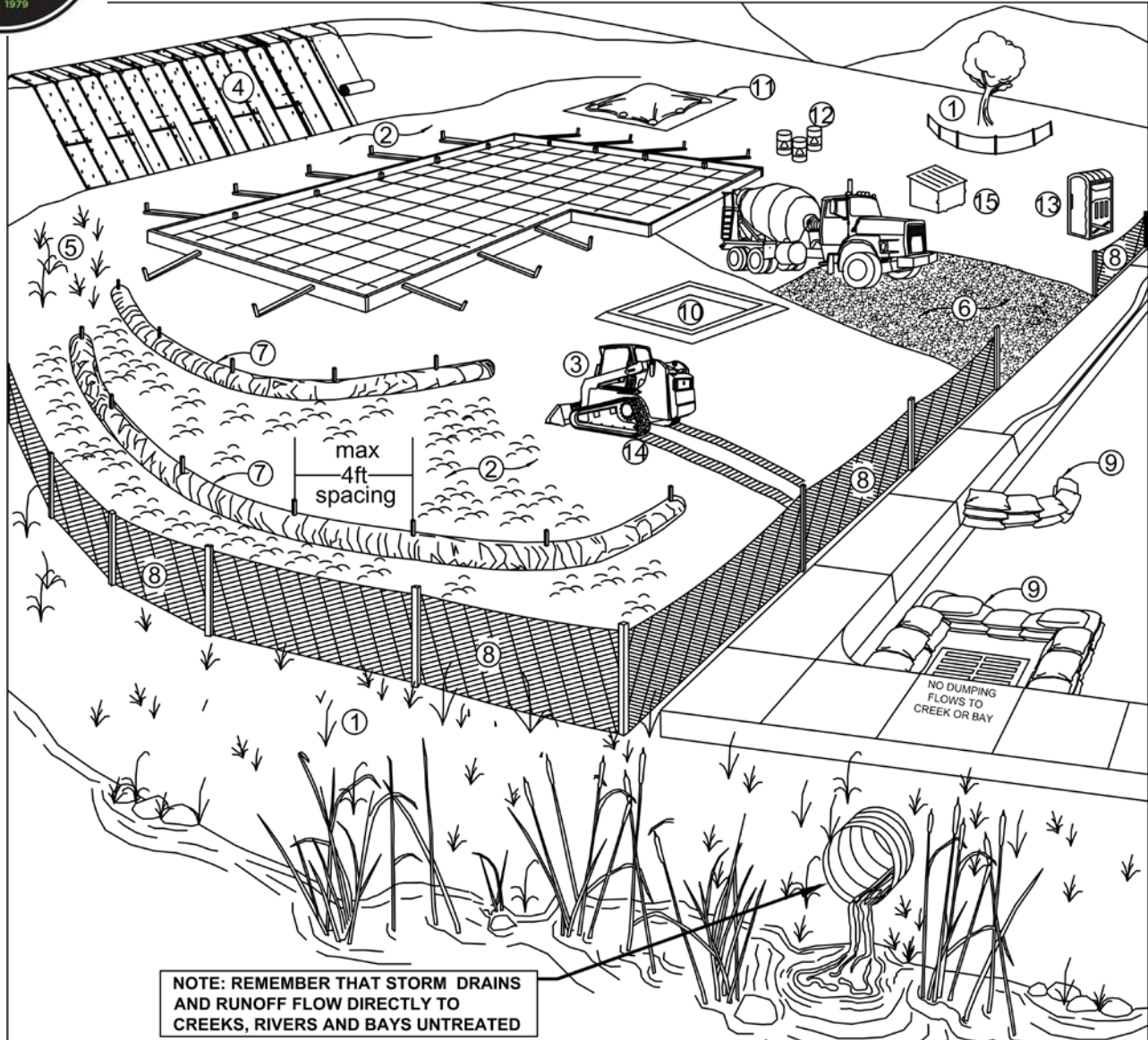

<u>Erosion Controls</u>	<u>Sediment Controls</u>	<u>Good Housekeeping</u>
NS Scheduling	6. Tracking Controls	10. Concrete Washout
1. Preserve Vegetation & Creek SetBacks	7. Fiber Rolls	11. Stockpile Management
2. Soil Cover	8. Silt Fence	12. Hazardous Material Management
3. Soil Preparation/ Roughening	9. Drain Inlet Protection	13. Sanitary Waste Management
4. Erosion Control Blankets	NS Trench Dewatering	14. Equipment and Vehicle Maintenance
5. Revegetation		15. Litter and Waste Management

NS=not shown on graphic

**Note:** Select an **effective combination of control measures from each category**, Erosion Control, Sediment Control, and Good Housekeeping. Control measures shall be **continually implemented and maintained throughout the project** until activities are complete, disturbed areas are stabilized with permanent erosion controls, and the local agency has signed off on permits that may have been required for the project. **Inspect and maintain the control measures** before and after rain events, and as required by the local agency or state permit.

More detailed information on the BMPs can be found in the related California Stormwater Quality Association (CASQA) and California Department of Transportation (Caltrans) BMP Factsheets. CASQA factsheets are available by subscription in the *California Best Management Practices Handbook Portal: Construction* at <http://www.casqa.org>. Caltrans factsheets are available in the *Construction Site BMP Manual March 2003* at <http://www.dot.ca.gov/hq/construc/stormwater/manuals.htm>.

Control Measure		General Description
<b>Erosion Control Best Management Practices</b>		
N/A	Scheduling	Plan the project and develop a schedule showing each phase of construction. Schedule construction activities to reduce erosion potential, such as scheduling ground disturbing activities during the summer and phasing projects to minimize the amount of area disturbed. <i>For more info see the following factsheets: CASQA: EC-1; or Caltrans: SS-1.</i>
1	Preserve Existing Vegetation and Creek Setbacks	Preserve existing vegetation to the extent possible, especially along creek buffers. Show creek buffers on maps and identify areas to be preserved in the field with temporary fencing. Check with the local Planning and Public Works Departments for specific creek set back requirements. <i>For more info see the following factsheets: CASQA: EC-2; or Caltrans: SS-2.</i>
2	Soil Cover	Cover exposed soil with straw mulch and tackifier (or equivalent). <i>For more info see the following factsheets: CASQA: EC-3, EC-5, EC-6, EC-7, EC-8, EC-14, EC-16; or Caltrans: SS-2, SS-4, SS-5, SS-6, SS-7, SS-8.</i>
3	Soil Preparation/Roughening	Soil preparation is essential to vegetation establishment and BMP installation. It includes soil testing and amendments to promote vegetation growth as well as roughening surface soils by mechanical methods (decompacting, scarifying, stair stepping, etc.). <i>For more info see the following factsheets: CASQA: EC-15.</i>
4	Erosion Control Blankets	Install erosion control blankets (or equivalent) on disturbed sites with 3:1 slopes or steeper. Use wildlife-friendly blankets made of biodegradable natural materials. Avoid using blankets made with plastic netting or fixed aperture netting. See: <a href="http://www.coastal.ca.gov/nps/Wildlife-Friendly_Products.pdf">http://www.coastal.ca.gov/nps/Wildlife-Friendly_Products.pdf</a> . <i>For more info see the following factsheets: CASQA: EC-7; or Caltrans: SS-7.</i>
5	Revegetation	Re-vegetate areas of disturbed soil or vegetation as soon as practical. <i>For more info see the following factsheets: CASQA: EC-4; or Caltrans: SS-4.</i>
<b>Sediment Control Best Management Practices</b>		
6	Tracking Controls	Stabilize site entrance to prevent tracking soil offsite. Inspect streets daily and sweep street as needed. Require vehicles and workers to use stabilized entrance. Place crushed rock 12-inches deep over a geotextile, using angular rock between 4 and 6-in. Make the entrance as long as can be accommodated on the site, ideally long enough for 2 revolutions of the maximum tire size (16-20 feet long for most light trucks). Make the entrance wide enough to accommodate the largest vehicle that will access the site, ideally 10 feet wide with sufficient radii for turning in and out of the site. Rumble pads or rumble racks can be used in lieu of or in conjunction with rock entrances. Wheel washes may be needed where space is limited or where the site entrance and sweeping is not effective. <i>For more info see the following factsheets: CASQA: TC-1; TC-3; or Caltrans: TC-1; TC-3.</i>
7	Fiber Rolls	Use fiber rolls as a perimeter control measure, along contours of slopes, and around soil stockpiles. On slopes space rolls 10 to 20 feet apart (using closer spacing on steeper slopes). Install parallel to contour. If more than one roll is used in a row overlap roll do not abut. J-hook end of roll upslope. Install rolls per either Type 1 (stake rolls into shallow trenches) or Type 2 (stake in front and behind roll and lash with rope). Use wildlife-friendly fiber rolls made of biodegradable natural materials. Avoid using fiber rolls made with plastic netting or fixed aperture netting. See: <a href="http://www.coastal.ca.gov/nps/Wildlife-Friendly_Products.pdf">http://www.coastal.ca.gov/nps/Wildlife-Friendly_Products.pdf</a> . Manufactured linear sediment control or compost socks can be used in lieu of fiber rolls. <i>For more info see the following factsheets: CASQA: SE-5 (Type 1); SE-12, SE-13; or Caltrans: SC-5 (Type 1 and Type 2).</i>
8	Silt Fence	Use silt fence as a perimeter control measure, and around soil stockpiles. Install silt fence along contours. Key silt fence into the soil and stake. Do not use silt fence for concentrated water flows. Install fence at least 3 feet back from the slope to allow for sediment storage. Wire backed fence can be used for extra strength. Avoid installing silt fence on slopes because they are hard to maintain. Manufactured linear sediment control can be used in lieu of silt fences. <i>For more info see the following factsheets: CASQA: SE-1; SE-12; or Caltrans: SC-1.</i>
9	Drain Inlet Protection	Use gravel bags, (or similar product) around drain inlets located both onsite and in gutter as a last line of defense. Bags should be made of a woven fabric resistant to photo-degradation filled with 0.5-1-in washed crushed rock. Do not use sand bags or silt fence fabric for drain inlet protection. <i>For more info see the following factsheets: CASQA: SE-10; or Caltrans: SC-10.</i>
N/A	Trench Dewatering	Follow MCSTOPPP BMPs for trench dewatering. <a href="http://www.marincounty.org/depts/pw/divisions/mcstoppp/development/~media/Files/Departments/PW/mcstoppp/development/TrenchingSWReqMCSTOPPPFinal6_09.pdf">http://www.marincounty.org/depts/pw/divisions/mcstoppp/development/~media/Files/Departments/PW/mcstoppp/development/TrenchingSWReqMCSTOPPPFinal6_09.pdf</a> . <i>For more info see the following factsheets: CASQA: NS-2; or Caltrans: NS-2.</i>
<b>Good Housekeeping Best Management Practices</b>		
10	Concrete Washout	Construct a lined concrete washout site away from storm drains, waterbodies, or other drainages. Ideally, place adjacent to stabilized entrance. Clean as needed and remove at end of project. <i>For more info see the following factsheets: CASQA: WM-8; or Caltrans: WM-8.</i>
11	Stockpile Management	Cover all stockpiles and landscape material and berm properly with fiber rolls or sand bags. Keep behind the site perimeter control and away from waterbodies. <i>For more info see the following factsheets: CASQA: WM-3 or Caltrans: WM-3.</i>
12	Hazardous Material Management	Hazardous materials must be kept in closed containers that are covered and within secondary containment; do not place containers directly on soil. <i>For more info see the following factsheets: CASQA: WM-6; or Caltrans: WM-6.</i>
13	Sanitary Waste Management	Place portable toilets near stabilized site entrance, behind the curb and away from gutters, storm drain inlets, and waterbodies. Tie or stake portable toilets to prevent tipping and equip units with overflow pan/tray (most vendors provide these). <i>For more info see the following factsheets: CASQA: WM-9; or Caltrans: WM-9.</i>
14	Equipment and Vehicle Maintenance	Prevent equipment fluid leaks onto ground by placing drip pans or plastic tarps under equipment. Immediately clean up any spills or drips. <i>For more info see the following factsheets: CASQA: NS-8, NS-9, and NS-10; or Caltrans: NS-8, NS-9, and NS-10.</i>
15	Litter and Waste Management	Designate waste collection areas on site. Use watertight dumpsters and trash cans; inspect for leaks. Cover at the end of each work day and when it is raining or windy. Arrange for regular waste collection. Pick up site litter daily. <i>For more info see the following factsheets: CASQA: WM-5; or Caltrans: WM-5.</i>

**Notes:**

1. Mats/blankets should be installed vertically downslope
2. Staple blankets sufficiently to ensure that material will maintain direct contact with soil

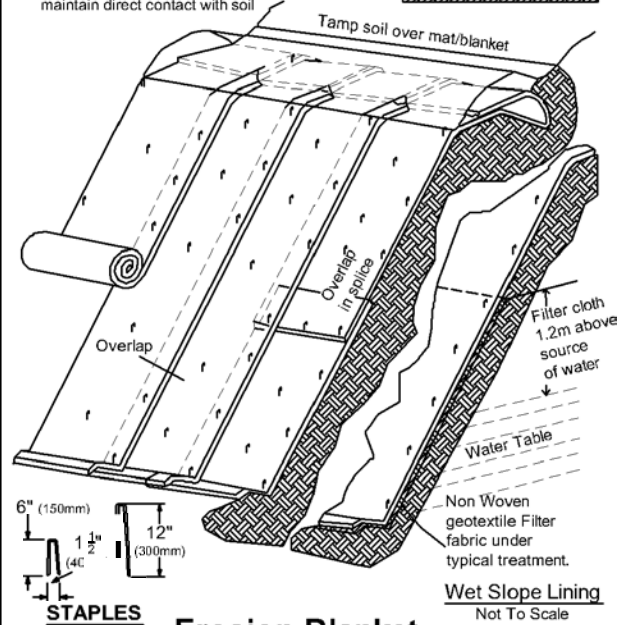

**Erosion Blanket**

Note: Actual layout determined in the field.

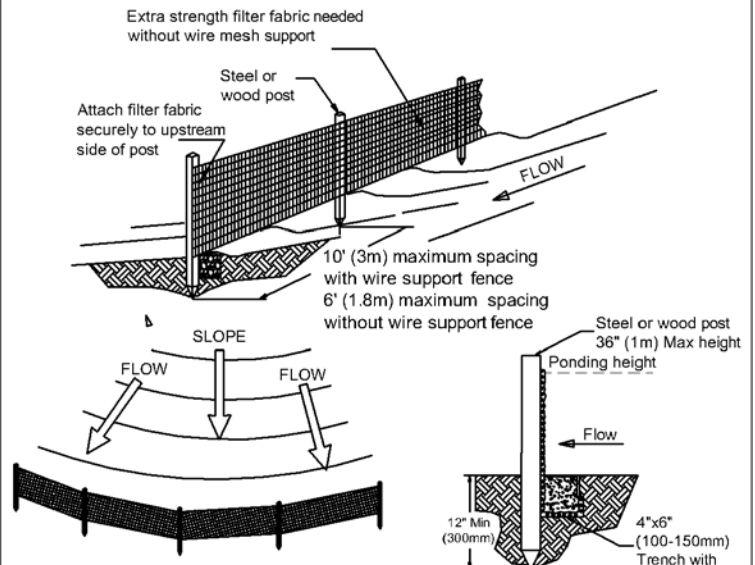

**Notes:**

1. Silt fence shall be placed level along slope contours to maximize ponding efficiency with the ends curved uphill to improve ability to retain water.
2. Inspect and repair fence after each storm event and remove sediment when accumulation reaches 1/3 of the barrier height.
3. Removed sediment shall be deposited to an area that will not contribute sediment off-site and can be permanently stabilized

**Silt Fence**

NOT TO SCALE

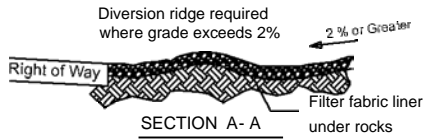

**Site Entrance**

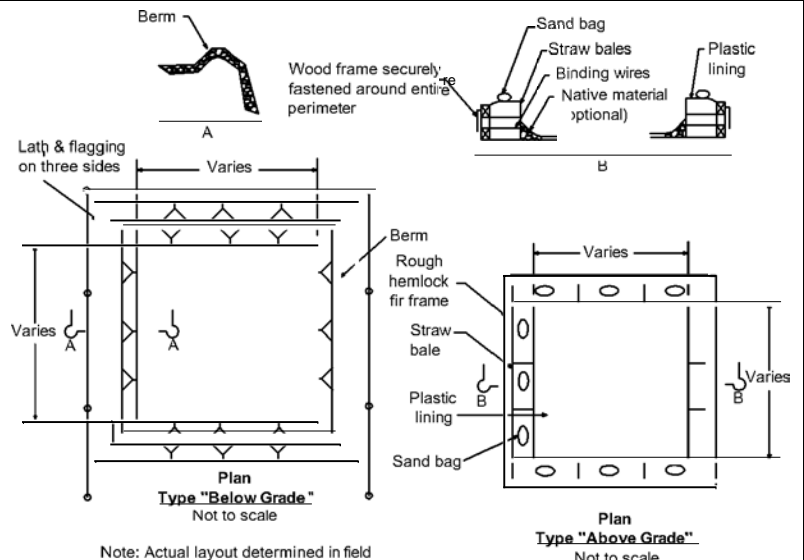

Note: Actual layout determined in field

**Concrete Washout**







# TOWN OF PARADISE CONSTRUCTION AND DEMOLITION DEBRIS RECYCLING WASTE MANAGEMENT PLAN (WMP)

Project No: \_\_\_\_\_ Staff Initials: \_\_\_\_\_ Date: \_\_\_\_\_ Approved:  Waived:  Not Approved:

**California Green Building Code requires a minimum of 65% diversion of job-site waste materials from the landfill.**

Please answer the following:

1.

Property Owner Name/Ph.#	
Job-site Address:	
Name of Project Manager:	
Address:	
Phone Number:	
Cellular Phone Number:	
Fax Number:	

- Identify the type of materials to be recycled, salvaged or disposed from the job-site in **Section I** of the waste assessment table on the back of this page.
- Identify how materials will be handled, who will haul materials or what facility materials will be going to in **Section I** of the waste assessment table on the back of this page.
- Section II** is to be filled out with supporting documentation upon completion of project.
- Briefly state how materials will be sorted for recycling and/or salvage on the job site.

---

---

---

---

---

---

---

---

- Will this project require the use of sub-contractors?                      Yes                      No  
If yes, briefly state how you plan to inform and ensure participation by the sub-contractors of your job-site recycling and waste management responsibility.

---

---

## WASTE ASSESSMENT

- I. BEFORE START OF PROJECT: Identify the materials that you estimate will be recycled, salvaged or landfilled. Identify the handling procedure, hauler and/or destination of each material type.
- II. UPON COMPLETION OF PROJECT: Indicate the material **types and quantities** recycled, salvaged or disposed from this job-site. Official weight tags must be submitted with this completed report identifying 1) job site address, 2) weight of load(s), 3) material type(s) and 4) if materials were recycled, salvaged or disposed.

Material Type	Section I Identify materials (✓)			Handling procedure, hauler or final destination of materials	Section II Quantity of each material (by weight)			Paradise use only Acceptable weight tag (staff initials)
	Recycle	Salvage	Landfill		Recycled	Salvaged	Landfilled	
Asphalt & Concrete								
Brick, Tile								
Building materials-doors, windows, fixtures, cabinets								
Cardboard								
Dirt/Clean Fill								
Drywall								
Carpet padding/ Foam								
Plate/window Glass								
Scrap Metals (steel, aluminum, brass, copper, etc.)								
Unpainted Wood & Pallets								
Yard Trimmings (brush, trees, stumps, etc.)								
Other:								
Garbage								
TOTALS								
% RECYCLED								%

<b>If no materials are targeted for recycling or salvage, please state why.</b>

\_\_\_\_\_  
Contractor's Signature / Date

\_\_\_\_\_  
Property Owner's Signature/Date

# Construction & Demolition (C & D) Recycling and Salvage Information

## General Waste Services:

- Northern Recycling & Waste Services 530-876-3340**
- Recology Butte Colusa Counties  
530-538-5868 / 530-342-2222
- Waste Management  
530-893-3340

## Material Recovery Facilities:

- Recology Butte Colusa Counties  
2720 S. 5<sup>th</sup> Ave, Oroville  
530-538-5868

## Inert Recycling Facilities:

- Neal Road Recycling & Waste Facility  
1023 Neal Rd, Paradise  
530-345-4917
- Knife River Construction  
Co. 1764 Skyway, Chico  
530-891-6555
- Granite Construction Co.  
4714 Pacific Heights Rd, Oroville  
530-538-7616

## Fixture & Building Materials:

- Re-Store (Habitat for Humanity)  
220 Meyers Chico  
530-895-1271

## Scrap Metal:

- Aldred Scrap & Steel Mill Recyclers  
786 Oro-Chico Hwy, Durham  
530-342-4930
- Chico Scrap Metal  
766 Oro-Chico Hwy,  
Durham 530-345-6241
- Norcal Recyclers  
1855 Kusel Rd,  
Oroville 530-532-0262

## Yard & Wood Wastes:

- Neal Road Recycling & Waste Facility  
1023 Neal Rd, Paradise  
530-345-4917
- Recology Butte Colusa Counties  
2720 S. 5<sup>th</sup> Ave, Oroville  
530-538-5868

## Cardboard

- Work Training Center  
2300 Fair St, Chico  
530-343-8641
- Chico Scrap Metal  
766 Oro-Chico Hwy,  
Durham 530-345-6241
- Norcal Recyclers  
1855 Kusel Rd,  
Oroville 530-532-0262

## Northern Recycling and Waste Services for the Town of Paradise:

920 American Way Paradise  
530-876-3340

Provides trash, debris, and Construction Waste Services for the Town of Paradise residences

*This partial list is for information purposes only and not an endorsement of any product or services.*







# Town of Paradise

Building Resiliency Center  
6295 Skyway, Paradise, CA 95969  
(530) 872-6291 Fax (530) 872-6201  
[www.townofparadise.com](http://www.townofparadise.com)

## LAND SURVEYOR'S CERTIFICATION GUIDELINES FOR BUILDING PERMIT

Surveys for property line locations are required to protect the property rights of the owner of a property where work is being done as well as the owners of adjacent properties by ensuring that setback requirements are being enforced.

Title 17 of the Paradise Municipal Code sets the minimum property line setbacks to structures, which are verified during the first building inspection, for each of the zoning districts within the Town of Paradise. The Professional Land Surveyors' Act (California Business & Professions Code §§ 8700-8805) specifies that a professional land surveyor, or California civil engineer authorized to practice land surveying (registered prior to 1982), is the only person licensed and authorized to determine and physically locate your property lines.

The following are the minimum submittal requirements for the Land Surveyor's Certification for Building Permit:

1. A completed Land Surveyor's Certification for Building Permit form to be stamped and signed by a Licensed Land Surveyor or Civil Engineer authorized to practice land surveying in the State of California.
2. An Exhibit plat prepared on an 8 ½ x 11" sheet showing the following:
  - a. The current configuration of the property as described in the current vesting deed, including all bearing and distances along the property lines.
  - b. Date.
  - c. North arrow.
  - d. Scale.
  - e. Assessor's Parcel Number.
  - f. Right(s) of Way and width of right(s) of way for all public and private roadways adjacent to property.
  - g. Location and description of found and set property corners.
  - h. Surveyor's signature and official stamp.

**LAND SURVEYOR'S CERTIFICATION  
FOR BUILDING PERMIT**

Permit Number: \_\_\_\_\_

Site Address: \_\_\_\_\_

Site APN: \_\_\_\_\_

Record Map Reference (if any):            Book            Page

Lot/Parcel Number as shown on said Map: \_\_\_\_\_

**Surveyor's Statement**

I hereby state that a field survey was performed by me on the real property described above, or under my direction, in conformance with the requirements of the Professional Land Surveyors' Act, Business and Professions Code §§ 8700 – 8805.

I also hereby state:

- That the monuments, as shown on the above referenced Record Map, have been found, verified as to their location and exposed for inspection as of the date of this statement, and are shown on the attached Exhibit.

And/or

- That missing property corner monuments have been set, or reset, as shown on the attached Exhibit and the appropriate Corner Record or Record of Survey will be filed with the County of Butte.
  
- That the monuments as described on the above referenced deed have been found, verified as to their location and exposed for inspection as of the date of this statement; are shown on the attached Exhibit; and a Record of Survey will be filed with the County of Butte.

This certification and the attached exhibit are for the sole purpose of the property corner identification of this parcel only and are not intended for public distribution or any use other than building permit clearance for the real property described above.

By: \_\_\_\_\_

Date: \_\_\_\_\_

\_\_\_\_\_  
(print name and license number)

Company Name: \_\_\_\_\_

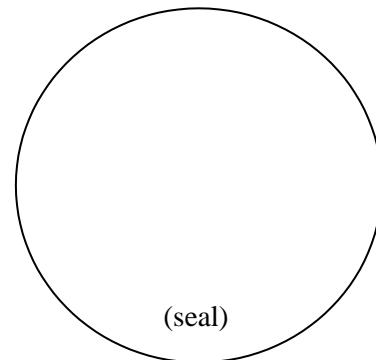

Attachment



**Town of Paradise**  
Public Works Department  
Engineering Division  
5555 Skyway  
Paradise, CA 95969  
(530) 872-6291

**Building Permit Driveway Affidavit**

I, \_\_\_\_\_, hereby depose and state as follows:

Project Address: \_\_\_\_\_ Building Permit No.: \_\_\_\_\_

**Questions**

1. The project for which I am seeking a building permit includes a driveway. If the answer is **YES**, continue. If **NO**, skip to Acknowledgement 2 .  
YES  
NO
2. If the answer to Question 1 is **YES**, will the driveway extend into the public right of way/roadway (beyond property line)? If the answer is **YES**, continue. If **NO**, skip to Acknowledgement 2.  
YES  
NO

**Acknowledgements**

1. If the driveway extends into the public right of way/roadway, I acknowledge that all work within the public right of way/roadway requires a valid encroachment permit from the Town of Paradise Public Works Department prior to any work starting in the public right of way/roadway.  
I ACKNOWLEDGE
2. If at any point during the construction work under this Building Permit, I decide to add a driveway which involves the public right of way/roadway, I will obtain a valid encroachment permit.  
I ACKNOWLEDGE
3. I have reviewed the attached Encroachment Permit Application and Standards provided for my reference. I agree to secure a valid encroachment based on the questions and acknowledgements made here in this form. If applicable, I agree to make the necessary contacts and construct driveway and drainage improvements in accordance with Town Standards.  
I ACKNOWLEDGE

**By signing below, I certify that all the information provided in this affidavit is true and accurate to the best of my knowledge.**

Applicant Name: \_\_\_\_\_ Applicant Signature: \_\_\_\_\_

Date: \_\_\_\_\_ Applicant Contact Number: \_\_\_\_\_

**Attachments:**  
Paradise Municipal Code Encroachment Permits  
Encroachment Permit Application  
Public Works Engineering Standard Details for Driveways



**ENCROACHMENT PERMIT APPLICATION**  
 SEE PAGE 2 FOR GENERAL CONDITIONS

Date Submitted: \_\_\_\_\_  
 Date Work Accepted: \_\_\_\_\_

Permit No.: \_\_\_\_\_  
 Work Zone: \_\_\_\_\_

Owner Information	
Name:	
Street Address:	
City, State, Zip:	Telephone No.:
Fax No.:	Mobile No.:

Submittal Items
Application
Traffic Control Plan (if req'd)
Insurance Certificates
Bond

Contractor Information	
Name:	
Street Address:	
City, State, Zip:	Telephone No.:
Fax No.:	Mobile No.:

Permit Fees	
Fee Type	
Amount	
Paid Date	
Received By	

**CONTRACTORS LICENSE LAW**

**I DECLARE UNDER PENALTY OF PERJURY (CHECK ONE):**

I am licensed under provisions of Chap. 9, Div. 3 of the Business and Professions Code and my license is in full force and effect for the scope of work which I am undertaking.  
 License type and number: \_\_\_\_\_

I, as the owner, or my employees with wages as their sole compensation, will do the work, and the structure is not intended or offered for sale. (sec. 7044)

I am exempt under sec. \_\_\_\_\_, Business and Professional Code for this reason \_\_\_\_\_.

**WORKERS COMPENSATION INSURANCE**

**I DECLARE UNDER PENALTY OF PERJURY (CHECK ONE):**

The permit is for \$500.00 (valuation) or less.

I have placed on file with the Town of Paradise Development Services Department a certificate of workers compensation insurance or a certificate of consent to self-insure.

I shall not employ any person in any manner so as to become subject to the Worker's Compensation laws of California.

**Notice to applicant:** If, after making this statement, should you become subject to Worker's Compensation provisions of the labor code, you must forthwith comply with such provisions or this permit shall be deemed revoked.

Project Information					
Excavate:	Street	Other:	Install:	Sidewalk	Utility
	Sidewalk			Curb/Gutter	Other:
	Curb/Gutter			Driveway	
	Driveway			Culvert (Confirm size and location, 15" min.)	
Location of Work:			Nearest Cross Street:		
Adjacent to Signalized Intersection:		Yes	No	*If within 300' in any direction, reference Note 14 on Page 2 of this application	
Anticipated Start Date:			Estimated End Date:		
Scope of Work:					
Contractor Job # or Project Name (if applicable):					

I certify that I have read this application and state that the above information is correct. I agree to comply with the General Conditions (see page 2) and to all Town Ordinances, Town Standards, State and Federal laws relating to construction, and hereby authorize representatives of the Town of Paradise to enter upon the above mentioned property for inspections purposes. I also agree to waive, indemnify and keep harmless the Town and its agents against all liabilities, judgments, costs, and expenses which may in any way accrue against said agency in consequence of the granting of this permit.

Property-owner / Contractor

\_\_\_\_\_  
*Applicant Signature* *Date* *(circle one)*

**Approval Special Conditions:** \_\_\_\_\_

**Approved by:** \_\_\_\_\_ **Date:** \_\_\_\_\_ **Inspection Contact No.:** \_\_\_\_\_





### **ENCROACHMENT PERMIT GENERAL CONDITIONS**

1. All contractors working on this project shall have proper insurance, with the General or Prime Contractor having liability insurance with a combined single limit of one million dollars, and also one million dollars limit for general aggregate; with the Town of Paradise named as an additional insured. This will be in standard form from your insurer, with a copy signed by your agent. No work shall commence without this insurance being provided. Additional insurance provisions can be found in Town of Paradise Municipal Code Section 12.14.150-160.
2. It is understood and agreed that the Town has prior right to the use of its Right-of-Way. It is further understood and agreed by the Permittee that the doing of any work under this permit shall constitute an acceptance of all the provisions contained herein and failure on the Permittee's part to comply with all provisions will be cause for revocation of this permit. Except as otherwise provided for public agencies and franchise holders, the permit is revocable at any time. This permit is to be on the job at all times while the work is being done.
3. All work shall be done subject to the supervision of and to the satisfaction of the Public Works Department of the Town. The Permittee shall, at all times during the progress of the work, keep the Town roadway in as neat and clean a condition as is possible and upon completion of the work granted herein, shall leave the Town roadway in a thoroughly neat, clean and usable condition.
4. The Permittee agrees by the acceptance of this permit to properly maintain any encroachment placed by the Permittee on any part of the Town roadway and to immediately repair any injury to any portion of the roadway which occurs as a result of the encroachment, until such time as the Permittee may be relieved of the responsibility of such encroachment by the Town Department of Public Works.
5. It is further agreed by the Permittee that whenever construction, reconstruction, or maintenance work upon the highway may require, the installation provided for herein shall, upon request of the Town Department of Public Works, be immediately removed by and at the sole expense of the Permittee.
6. No material used for fill or backfill in the construction of the encroachment shall be borrowed or taken from within the Town Right-of-Way.
7. Where applicable, Permittee shall submit proposed traffic control plan. All traffic control methods shall be California MUTCD Part 6 compliant. At least one eleven foot (11') lane in each direction of any public road, under the jurisdiction of the Town of Paradise, and other public roads junctioning or intersecting therewith, shall be kept open for travel by the general public at all times. Reversible flow, one-way traffic control requires specific approval during the Application Review Process. A full traffic control plan shall be submitted for review when controls exceed typical flagging or shoulder work, such as lane closures or lane shifts. No public road under the jurisdiction of the Town shall be closed to travel by the general public without special permission, in writing, of the Town Engineer.
8. The Permittee, by the acceptance of this permit, shall assume full responsibility for all liability for personal injury or damage to property which may arise out of the work herein permitted or which may arise out of the failure on the part of the Permittee to do the work provided for under this permit. In the event any claim of such liability is made against the Town or any department, official, or employee thereof, the Permittee shall defend, indemnify, and hold them and each of them harmless for such a claim.
9. Trench backfill and pavement restoration shall comply with Standard Detail **TB1** and Detail **TB2**, where applicable. All excavations shall be backfilled and compacted immediately after work therein has been completed. Trenches shall not be left open farther than 300 feet in advance of the pipe laying operations unless otherwise permitted by the engineer. Unless otherwise permitted under the special conditions, backfill shall be placed and mechanically compacted in such a manner that the relative compaction throughout the entire fill within the Town road right-of-way shall conform to the percentage of compaction as stated on Town standard details. Permittee shall notify the Town inspector **24** hours before backfilling and / or paving.
  - a. All installations, parallel with roadway, shall be placed as close to the right-of-way as possible.
  - b. All pavements, curbs, gutters, sidewalks, borrow ditches, pipes, headwalls, road signs, trees, shrubbery and / or other permanent road facilities impaired by or as a result of, construction operations at the construction site(s), or at other location(s) occupied by materials and / or equipment shall be restored immediately upon backfilling of the excavation to the original grades and cross sections, and to a condition as good as, or better than, existing prior to construction.
10. Whenever necessary to secure permission from abutting property owners, such authority must be secured by the Permittee prior to starting work.
11. The future safety and convenience of the traveling public shall be given every consideration in the location and type of construction. Permittee shall cause to be placed, erected and maintained all warning signals, lights, barricades, signs, and other devices or measures essential to safeguard travel by the general public over and at the site of work authorized herein.
12. If the construction work covered by this permit is to be done by a private contractor hired by the applicant, applicant shall notify contractor as to the special conditions and requirements contained herein.
13. Permittee agrees that if the roadway and / or adjacent area (including drainage or stormwater pollution best management practices) are not left in an acceptable manner to the Town Engineer, and if such noticed deficiencies are not corrected within thirty (30) days of written notice thereof, Permittee agrees to pay the Town of Paradise for any and all costs necessary to correct said deficiencies.
14. When any excavation is to take place within 300 feet of a signalized intersection, Permittee shall secure location service of signal loop and wiring from Bear Electrical Solutions (1-800-462-3271) and shall be required to pay for that service.
15. This permit expires one (1) year from the approval date unless otherwise noted. If you require an extension of time, please contact the Town Engineer's office.
16. A minimum of 24-hours notice is required to schedule an inspection by the Town in connection with this encroachment permit. Should the Contractor wish to perform work during non-typical working hours (M-F 7AM-5PM), the Contractor may request a special inspection for approval by the Town of Paradise. Such inspections, if approved, will be billed to the Contractor at rates defined in the Master Fee Schedule currently in effect.
17. Contractor shall notify Underground Service Alert (USA) at least 48 hours in advance of any work; dial 811.

DRIVEWAY TYPE	CALTRANS TYPE A, 1/2" MAX AGGREGATE ASPHALT CONCRETE	CL II AB ROCK, 95% COMPACTED
	MINIMUM THICKNESS	MINIMUM THICKNESS
RESIDENTIAL	2½"	4"
COMMERCIAL	4"	6"

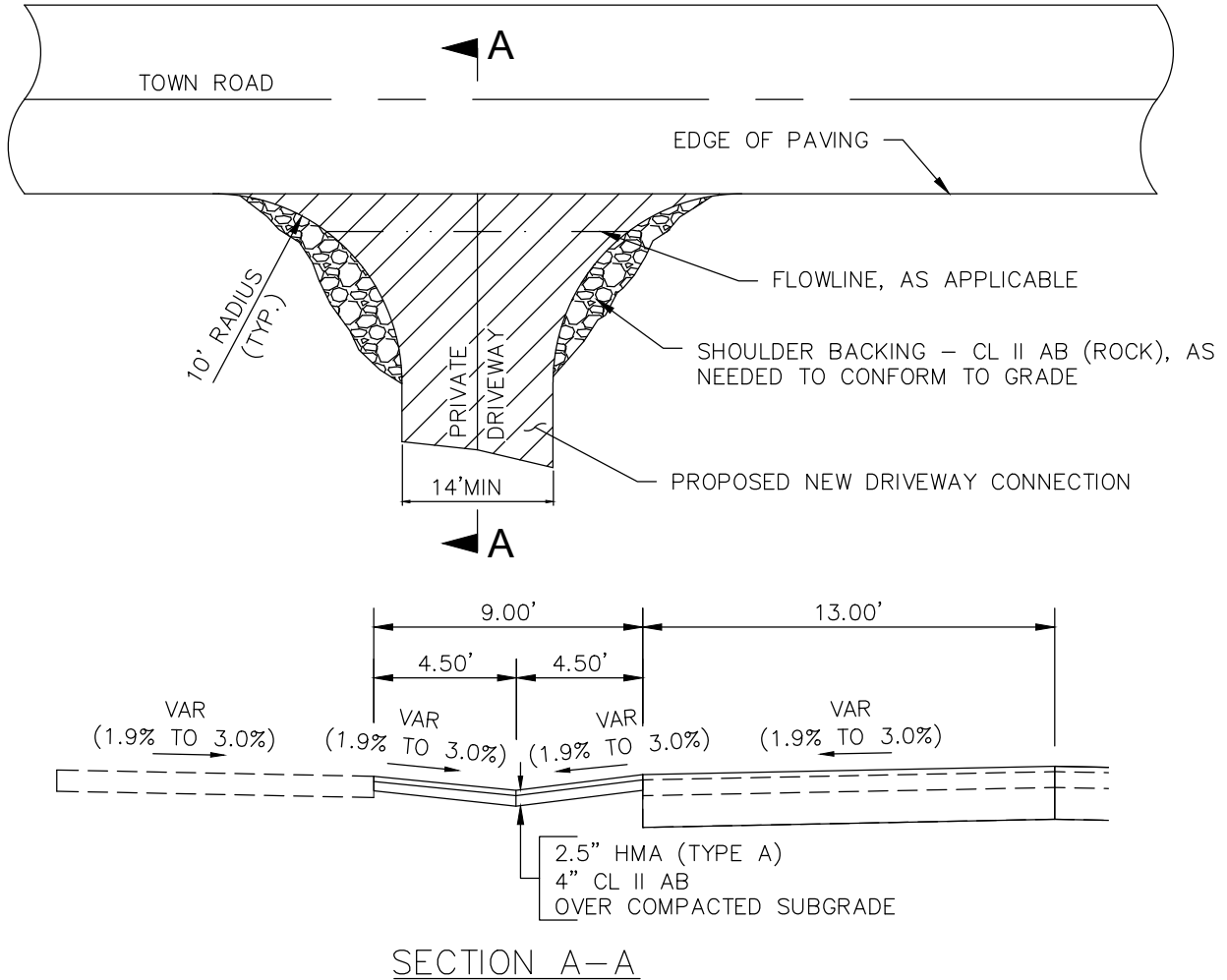

**NOTES:**

1. DRIVEWAY SLOPE AND LAYOUT TO BE APPROVED BY TOWN OF PARADISE.
2. CONTACT TOWN OF PARADISE (OR CALTRANS FOR SR 191/CLARK RD SOUTH OF PEARSON) PRIOR TO BEGINNING WORK.
3. PRIOR TO PLACING ASPHALT CONCRETE THE SAWCUT EDGE IS TO HAVE A SS-1 TACK COAT APPLIED.
4. PAVING SURFACE AT BUTT JOINTS SHALL BE SEALED WITH SS-1 EMULSION 4" EACH SIDE OF JOINT AFTER FINAL COMPACTION OF ASPHALT CONCRETE. SEALANT SHALL BE SANDED AS NECESSARY TO PREVENT TRAFFIC PICK UP.
5. THE DRIVEWAY APPROACH SECTION SHALL BE A MINIMUM OF 2 1/2" ASPHALT CONCRETE ON 4" CL II AB ROCK FOR RESIDENTIAL APPROACHES AND 4" ASPHALT CONCRETE ON 6" CL II AB ROCK FOR COMMERCIAL DRIVE APPROACHES. ASPHALT CONCRETE SHALL BE CALTRANS TYPE 'A', 1/2" MAXIMUM AGGREGATE ASPHALT CONCRETE. BASE ROCK SHALL BE COMPACTED TO 95%.
6. ASPHALT CONCRETE PLACEMENT AT TOWN ROAD IS TO BE A FLUSH BUTT JOINT. TIE INTO PUBLIC ROAD AT EXISTING EDGE OF PAVEMENT IN NEAT, STRAIGHT LINE. PRIOR TO SAWCUTTING ANY PUBLIC ROAD, OBTAIN APPROVAL FROM THE TOWN OF PARADISE.
7. ALL WORK SHALL CONFORM TO THE STANDARD SPECIFICATIONS OF THE STATE OF CALIFORNIA, DEPARTMENT OF TRANSPORTATION, CURRENT EDITION.
8. NO ADDITIONAL DRAINAGE WATER SHALL BE DIRECTED TO THE TOWN RIGHT OF WAY.



**TOWN OF PARADISE  
PUBLIC WORKS / ENGINEERING**

5555 Skyway  
Paradise, California 95969  
Phone: (530) 872-6291 Fax: (530) 877-5059

**Standard Detail D-12  
DRIVEWAY CONNECTION**

*[Signature]*  
Approved

3/30/2023  
Date

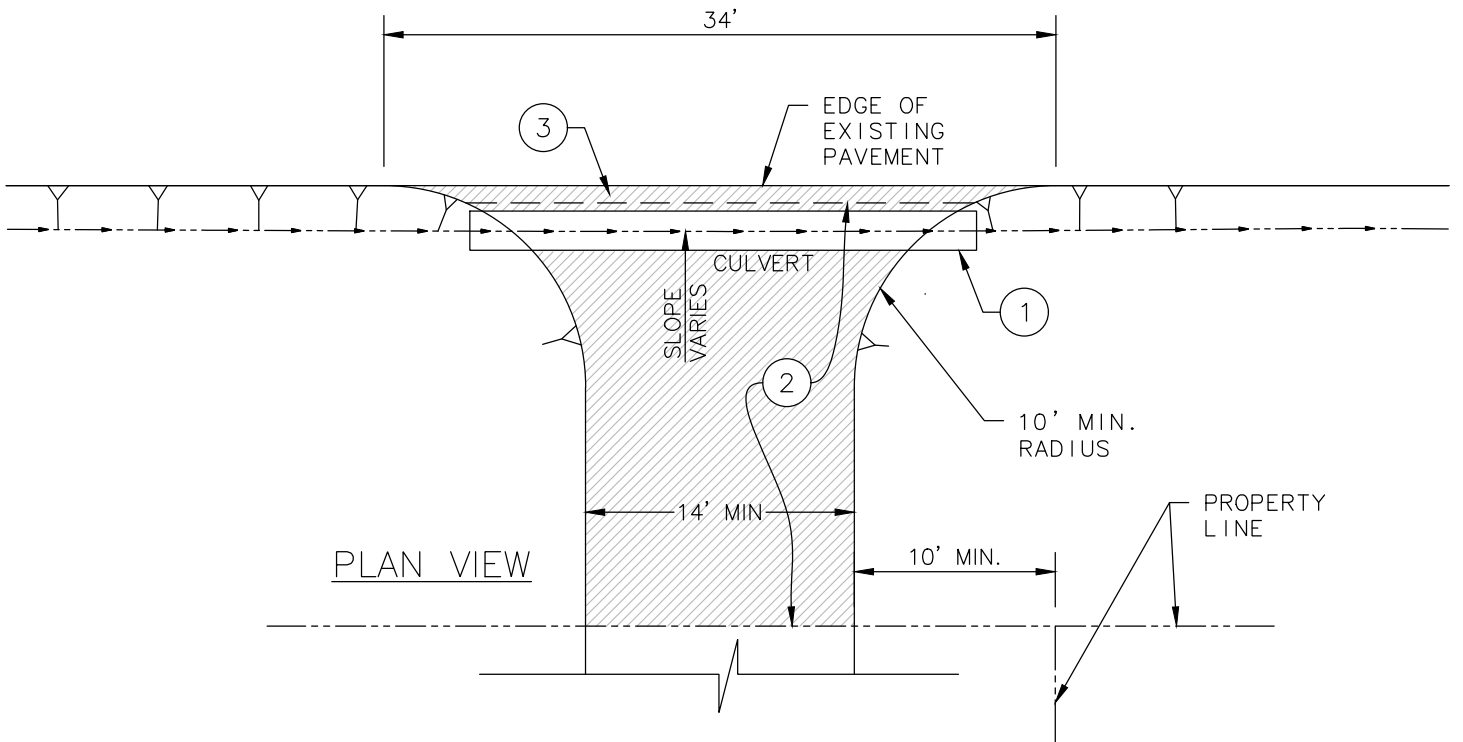

PLAN VIEW

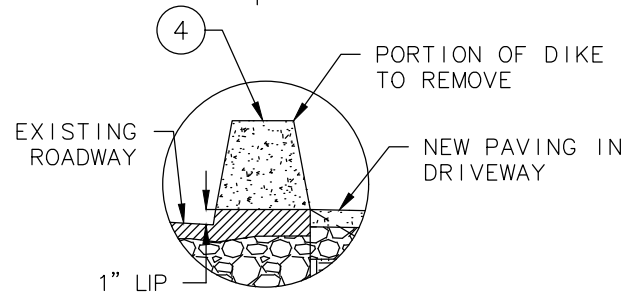

STREETS WITH EXISTING DIKE PROFILE

**NOTES:**

1. PIPE, IF REQUIRED BY TOWN ENGINEER, TO BE RCP OR EQUAL. SIZE, LENGTH, AND LOCATION TO BE DETERMINED BY TOWN ENGINEER. 15" MIN, OBLONG IF NEEDED OR OTHERWISE APPROVED.
2. PAVING SURFACE SHALL CONSIST OF 2.5" ASPHALT CONCRETE (AC) OVER 4" CL II AB OR OPTIONAL 4" CONCRETE OVER 2" AB, SAND, OR PEA GRAVEL. INSPECTION OF FORM ARE REQUIRED.
3. CONCRETE TRANSITION TO ASPHALT SHALL BE FLUSH.
4. REMOVE EXISTING AC DIKE IF APPLICABLE (KEEP 1" LIP AS SHOWN)
5. DRIVEWAY SHALL NOT OBSTRUCT NATURAL DRAINAGE DURING AND AFTER CONSTRUCTION.



**TOWN OF PARADISE**  
PUBLIC WORKS / ENGINEERING

5555 Skyway

Paradise, California 95969

Phone: (530) 872-6291 Fax: (530) 877-5059

Standard Detail D-13A  
PRIVATE DRIVEWAY

*[Signature]* 3/30/2023  
Approved Date