

ROLLED CURB & GUTTER SECTION

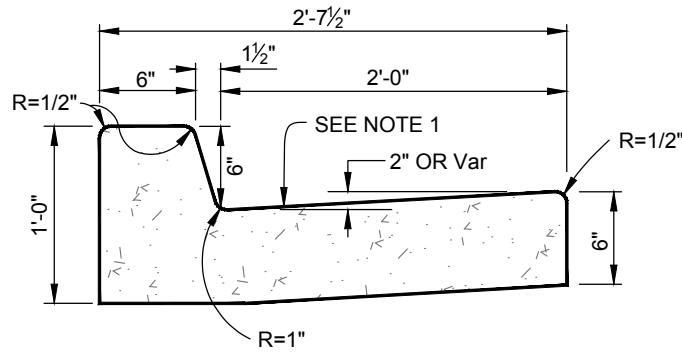

TYPE A2-6 CURB

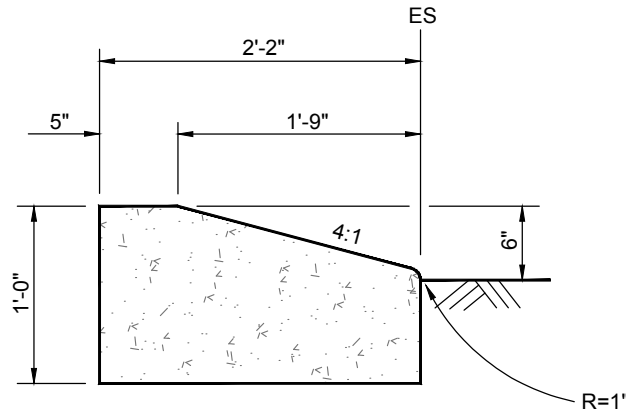

TYPE D-6 CURB

NOTES:

1. ACROSS THE PEDESTRIAN ROUTE AT CURB RAMP LOCATIONS, THE GUTTER PAN SLOPE SHALL NOT EXCEED 1" OF DEPTH FOR EACH 2'-0" OF WIDTH
2. AC PAVING ADJACENT TO ALL GUTTERS SHALL BE 1/4" ABOVE THE LIP OF GUTTER EXCEPT FOR WHEN IN ADA PATH OF TRAVEL.
3. INSTALL 1/4" WIDE EXPANSION JOINTS AT 48' MAX. INTERVALS AND 1/8" SCORED CONTROL JOINTS AT 12' MAX. INTERVALS ON ALL CURBS AND GUTTERS.
4. PLACE AGGREGATE BASE UNDER CURB AND GUTTER TO DEPTH OF STRUCTURAL SECTION. (3" MINIMUM THICKNESS)



TOWN OF PARADISE
PUBLIC WORKS / ENGINEERING

5555 Skyway
Paradise, California 95969
Phone: (530) 872-6291 Fax: (530) 877-5059

Standard Detail D-2A
CURB & GUTTER

[Signature]
Approved

3/30/2023
Date