

SEE ST-1 FOR STRUCTURAL SECTION

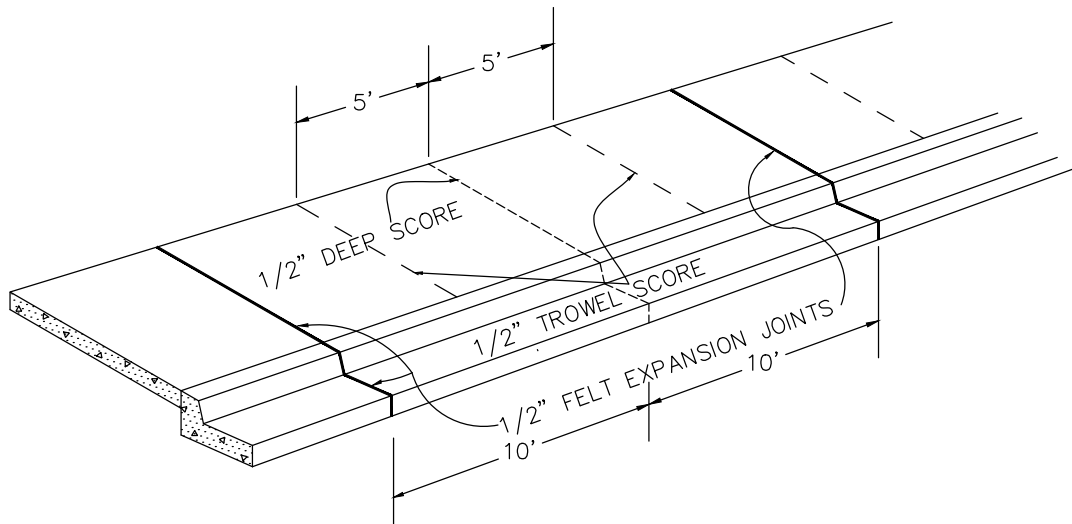

NOTES:

1. PROVIDE 1/2" DEEP SCORE AT 5' INTERVALS IN SIDEWALK.
2. 1/2" FELT EXPANSION JOINTS AT 20' INTERVAL FOR SIDEWALK.
3. 1/2" FELT EXPANSION JOINTS AT 20' INTERVAL FOR CURB & GUTTER.
4. CURB & GUTTER TO HAVE 1/2" DEEP SCORE @ 10' INTERVALS.
5. EXPANSION JOINTS IN SIDEWALK TO BE ADJACENT TO EXPANSION JOINTS IN CURB & GUTTER.
6. ALL EXPANSION JOINTS SHALL EXTEND COMPLETELY THROUGH CONCRETE.
7. CONCRETE FOR CURBS, SIDEWALKS AND THEIR APPURTENANCES MUST BE MINOR CONCRETE CONTAINING AT LEAST 463 POUNDS OF CEMENTITIOUS MATERIAL PER CUBIC YARD OR MEET CALTRANS REQUIREMENTS IN THE STANDARD SPECIFICATIONS SECTIONS 73 & 90.
8. SIDEWALK TO HAVE A TRANSVERSED BROOMED SURFACE TEXTURE.
9. SIDEWALK SHALL BE POURED SEPARATELY FROM CURB UNLESS OTHERWISE APPROVED BY THE TOWN ENGINEER.



TOWN OF PARADISE
PUBLIC WORKS / ENGINEERING

5555 Skyway
Paradise, California 95969

Phone: (530) 872-6291 Fax: (530) 877-5059

Standard Detail D-4A
ATTACHED SIDEWALKS CURB &
GUTTER

[Signature]
Approved

3/30/2023
Date