

SINGLE SIGN  
DETAIL

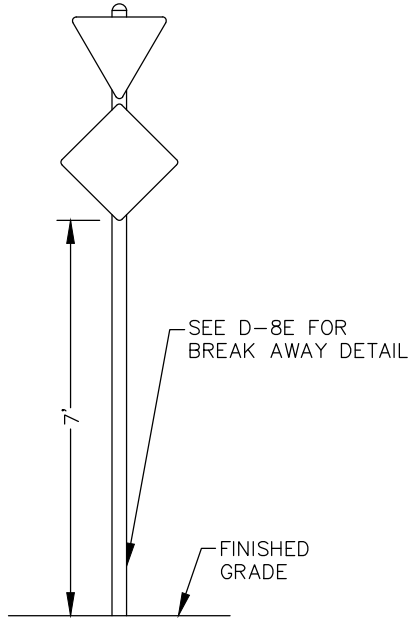

MULTIPLE SIGN  
DETAIL

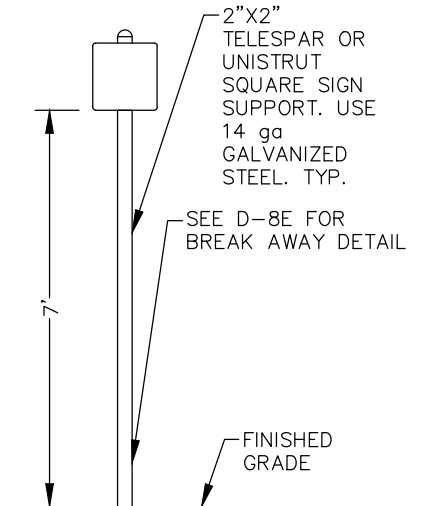

SIDEWALK OR  
MEDIAN DETAIL

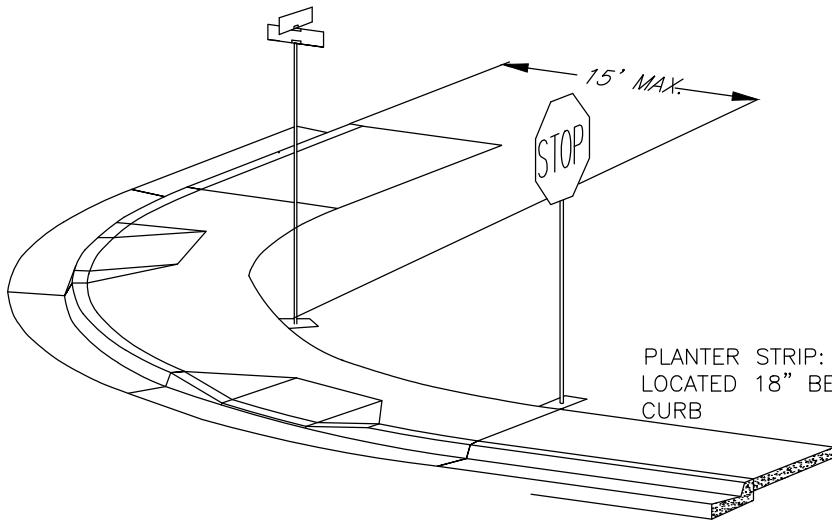

PLANTER STRIP: SIGN  
LOCATED 18" BEHIND  
CURB

NOTES:

1. GENERALLY, SIGNS ARE TO BE INSTALLED ON THE NEAR LEFT AND FAR RIGHT INTERSECTION CORNERS ON MAJOR STREETS.
2. THE ENGINEER IS TO DETERMINE THE SIZE OF THE POST HOLE FOR MULTIPLE SIGN POSTS BASED ON THE LOAD.
3. 18" MINIMUM CLEARANCE REQUIRED BACK OF WALK AND EDGE OF SIGN PROJECTION.



**TOWN OF PARADISE**  
PUBLIC WORKS / ENGINEERING

5555 Skyway  
Paradise, California 95969  
Phone: (530) 872-6291 Fax: (530) 877-5059

Standard Detail D-8C  
STREET SIGNS

*[Signature]*  
Approved Date 3/30/2023