

Standard Symbol

**BMP Objectives**

- Soil Stabilization
- Sediment Control
- Tracking Control
- Wind Erosion Control
- Non-Storm Water Management
- Materials and Waste Management

**Definition and Purpose** A silt fence is a temporary linear sediment barrier of permeable fabric designed to intercept and slow the flow of sediment-laden sheet flow runoff. Silt fences allow sediment to settle from runoff before water leaves the construction site.

- Appropriate Applications** Silt fences are placed:
- Below the toe of exposed and erodible slopes.
  - Down-slope of exposed soil areas.
  - Around temporary stockpiles.
  - Along streams and channels.
  - Along the perimeter of a project.

- Limitations**
- Not effective unless trenched and keyed in.
  - Not intended for use as mid-slope protection on slopes greater than 1:4 (V:H).
  - Must be maintained.
  - Must be removed and disposed of.
  - Don't use below slopes subject to creep, slumping, or landslides.
  - Don't use in streams, channels, drain inlets, or anywhere flow is concentrated.
  - Don't use silt fences to divert flow.

## Standards and Specifications ***Design and Layout***

- The maximum length of slope draining to any point along the silt fence shall be 61 m (200 ft) or less.
- Slope of area draining to silt fence shall be less than 1:1 (V:H).
- Limit to locations suitable for temporary ponding or deposition of sediment.
- Fabric life span generally limited to between five and eight months. Longer periods may require fabric replacement.
- Silt fences shall not be used in concentrated flow areas.
- Lay out in accordance with Pages 5 and 6 of this BMP.
- For slopes steeper than 1:2 (V:H) and that contain a high number of rocks or large dirt clods that tend to dislodge, it may be necessary to install additional protection immediately adjacent to the bottom of the slope, prior to installing silt fence. Additional protection may be a chain link fence or a cable fence.
- For slopes adjacent to water bodies or Environmentally Sensitive Areas (ESAs), additional temporary soil stabilization BMPs shall be used.

## ***Materials***

- Silt fence fabric shall be woven polypropylene with a minimum width of 900 mm (36 inches) and a minimum tensile strength of 0.45-kN. The fabric shall conform to the requirements in ASTM designation D4632 and shall have an integral reinforcement layer. The reinforcement layer shall be a polypropylene, or equivalent, net provided by the manufacturer. The permittivity of the fabric shall be between  $0.1 \text{ sec}^{-1}$  and  $0.15 \text{ sec}^{-1}$  in conformance with the requirements in ASTM designation D4491. Contractor must submit certificate of compliance in accordance with Standard Specifications Section 6-1.07.
- Wood stakes shall be commercial quality lumber of the size and shape shown on the plans. Each stake shall be free from decay, splits or cracks longer than the thickness of the stake or other defects that would weaken the stakes and cause the stakes to be structurally unsuitable.
- Bar reinforcement may be used, and its size shall be equal to a number four (4) or greater. End protection shall be provided for any exposed bar reinforcement.
- Staples used to fasten the fence fabric to the stakes shall be not less than 45 mm (1.75 inches) long and shall be fabricated from 1.57 mm (0.06 inch) or heavier wire. The wire used to fasten the tops of the stakes together when

---

joining two sections of fence shall be 3.05 mm (0.12 inch) or heavier wire. Galvanizing of the fastening wire is not required.

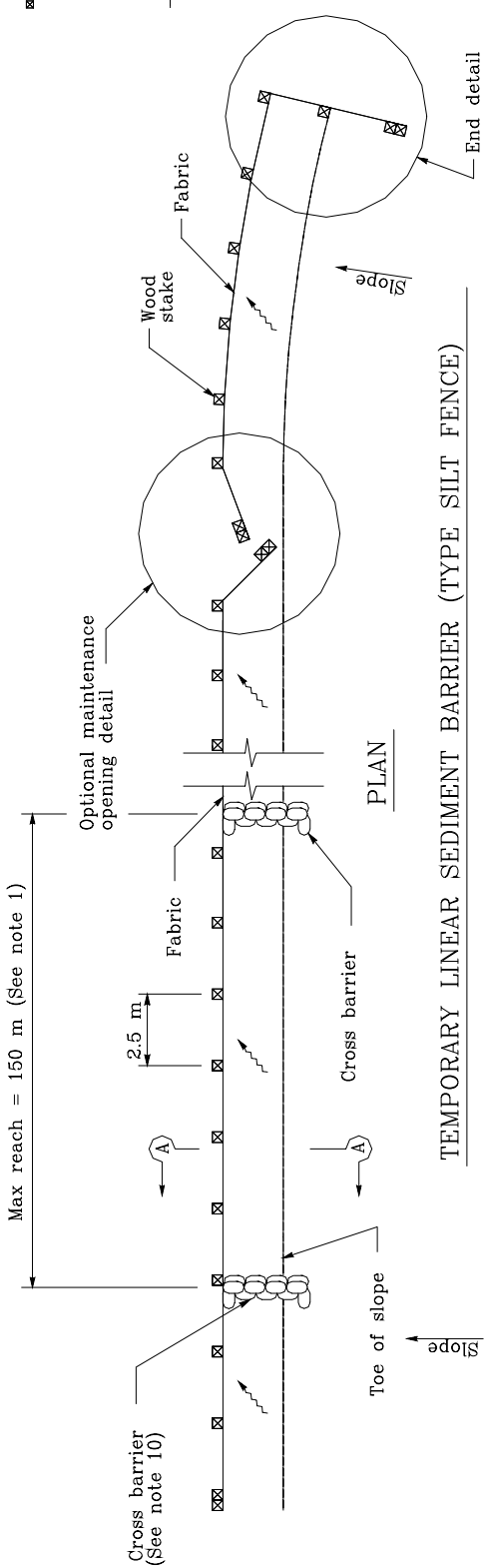
## ***Installation***

- Generally, silt fences shall be used in conjunction with soil stabilization source controls up slope to provide effective erosion and sediment control.
- Bottom of the silt fence shall be keyed-in a minimum of 150 mm (12 inches).
- Trenches shall not be excavated wider and deeper than necessary for proper installation of the temporary linear sediment barriers.
- Excavation of the trenches shall be performed immediately before installation of the temporary linear sediment barriers.
- Construct silt fences with a set-back of at least 1m (3 ft) from the toe of a slope. Where a silt fence is determined to be not practical due to specific site conditions, the silt fence may be constructed at the toe of the slope, but shall be constructed as far from the toe of the slope as practical.
- Construct the length of each reach so that the change in base elevation along the reach does not exceed 1/3 the height of the barrier; in no case shall the reach exceed 150 meters (490 ft).
- Cross barriers shall be a minimum of 1/3 and a maximum of 1/2 the height of the linear barrier.
- Install in accordance with Pages 5 and 6 of this BMP.

## Maintenance and Inspection

- Repair undercut silt fences.
- Repair or replace split, torn, slumping, or weathered fabric.
- Inspect silt fence when rain is forecast. Perform necessary maintenance, or maintenance required by the Resident Engineer (RE).
- Inspect silt fence following rainfall events. Perform maintenance as necessary, or as required by the RE.
- Maintain silt fences to provide an adequate sediment holding capacity. Sediment shall be removed when the sediment accumulation reaches one-third (1/3) of the barrier height. Removed sediment shall be incorporated in the project at locations designated by the RE or disposed of outside the right-of-way in conformance with the Standard Specifications.
- Silt fences that are damaged and become unsuitable for the intended purpose, as determined by the RE, shall be removed from the site of work, disposed of outside the highway right-of-way in conformance with the Standard Specifications, and replaced with new silt fence barriers.

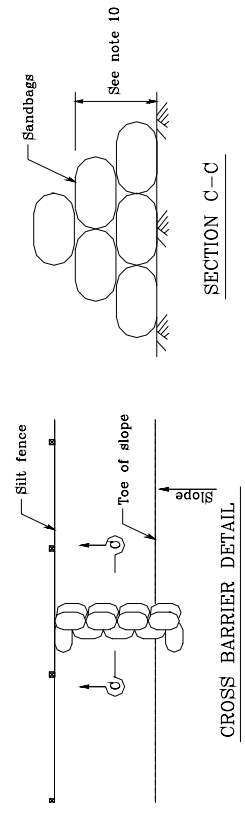
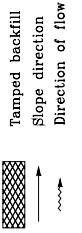
- 
- Holes, depressions or other ground disturbance caused by the removal of the temporary silt fences shall be backfilled and repaired in conformance with the Standard Specifications.
  
  - Remove silt fence when no longer needed or as required by the RE. Fill and compact post holes and anchorage trench, remove sediment accumulation, and grade fence alignment to blend with adjacent ground.



**NOTES**

1. Construct the length of each reach so that the change in base elevation along the reach does not exceed 1/3 the height of the linear barrier, in no case shall the reach length exceed 150m.
2. The last 2.5 m of fence shall be turned up slope.
3. Stake dimensions are nominal.
4. Dimension may vary to fit field condition.
5. Stakes shall be spaced at 2.5 m maximum and shall be positioned on downstream side of fence.
6. Stakes to overlap and fence fabric to fold around each stake one full turn. Secure fabric to stake with 4 staples.
7. Stakes shall be driven tightly together to prevent potential flow-through of sediment at joint. The tops of the stakes shall be secured with wire.
8. For end stake, fence fabric shall be folded around two stakes one full turn and secured with 4 staples.
9. Minimum 4 staples per stake. Dimensions shown are typical.
10. Cross barriers shall be a minimum of 1/3 and a maximum of 1/2 the height of the linear barrier.
11. Maintenance openings shall be constructed in a manner to ensure sediment remains behind silt fence.
12. Joining sections shall not be placed at sump locations.
13. Sandbag rows and layers shall be offset to eliminate gaps.

**LEGEND**



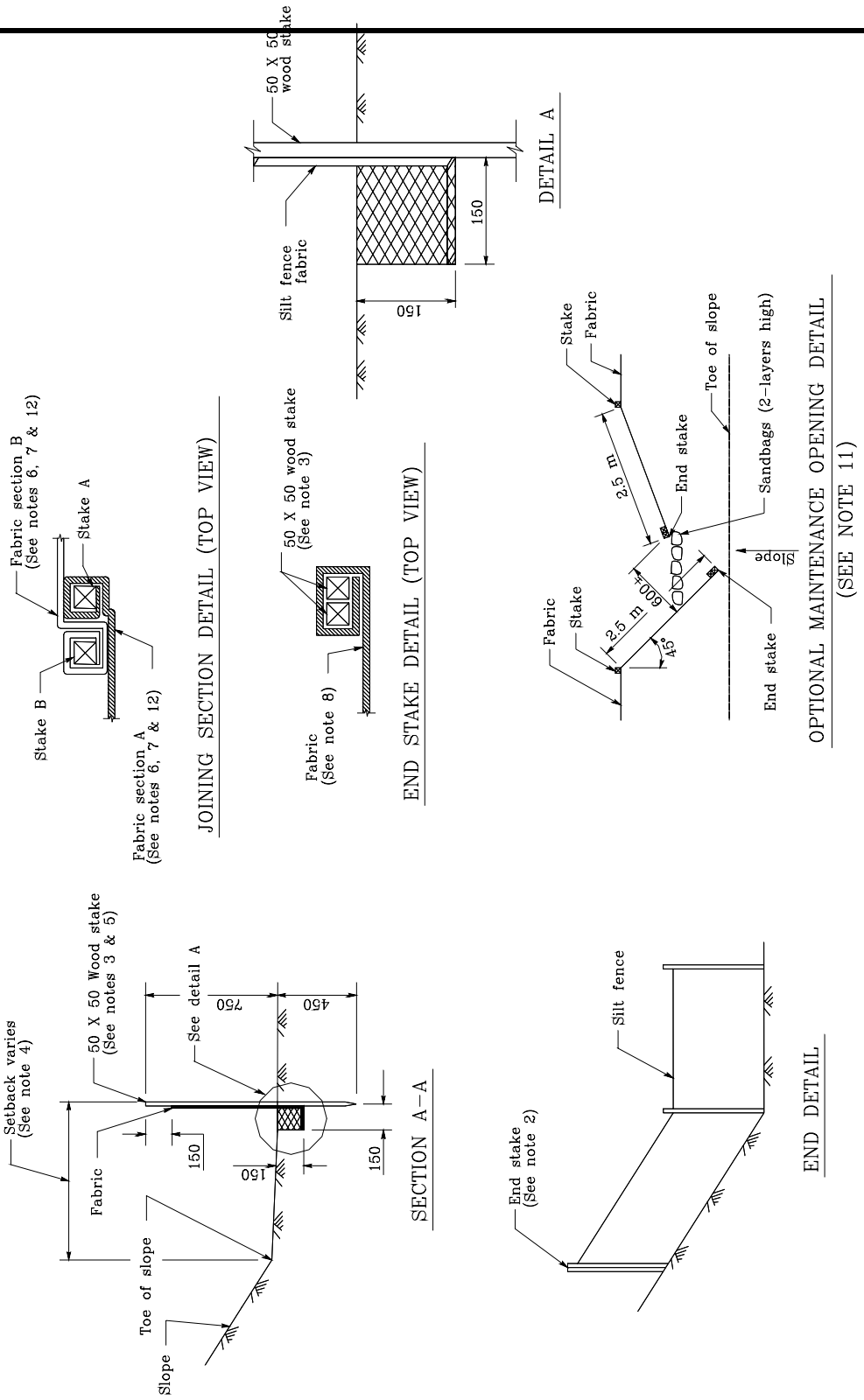
**SECTION C-C**

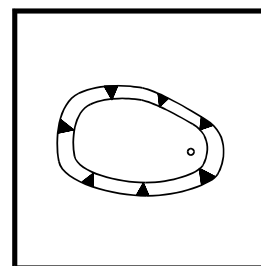
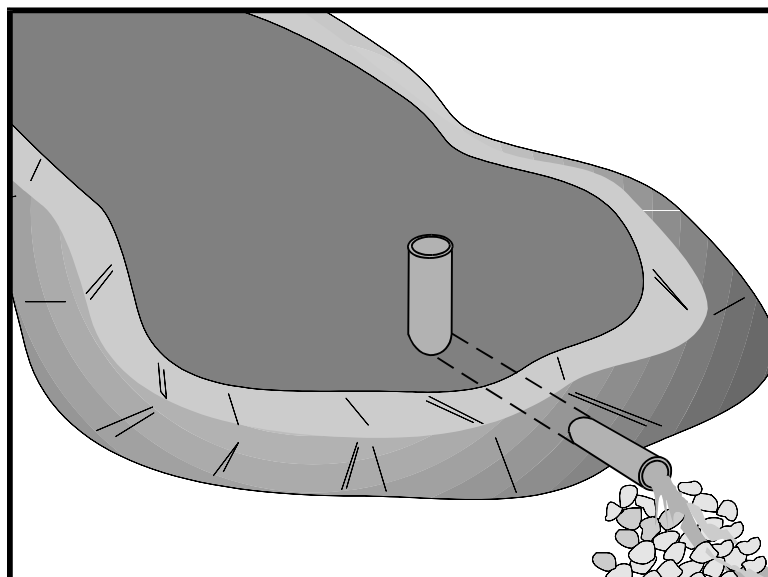
STATE OF CALIFORNIA  
DEPARTMENT OF TRANSPORTATION

**TEMPORARY LINEAR SEDIMENT BARRIER**  
**(TYPE SILT FENCE)**

NO SCALE

ALL DIMENSIONS ARE IN  
MILLIMETERS UNLESS OTHERWISE SHOWN





Standard Symbol

- BMP Objectives**

  - Soil Stabilization
  - Sediment Control
  - Tracking Control
  - Wind Erosion Control
  - Non-Storm Water Management
  - Materials and Waste Management

**Definition and Purpose** A sediment/desilting basin is a temporary basin formed by excavating and/or constructing an embankment so that sediment-laden runoff is temporarily detained under quiescent conditions, allowing sediment to settle out before the runoff is discharged (refer to Figures 1 and 2).

**Appropriate Applications** Sediment basins shall be designed in accordance with Section A of the State of California NPDES General Permit for Storm Water Discharges Associated with Construction Activities (General Permit). If there is insufficient area to construct a sediment basin in accordance with the General Permit requirements, then the alternate desilting design standards specified herein may be used. This BMP may be implemented on a project-by-project basis with other BMPs when determined necessary and feasible by the RE.

Sediment/Desilting Basins shall be considered for use:

- On construction projects with disturbed areas during the rainy season.
- Where sediment-laden water may enter the drainage system or watercourses.
- At outlets of disturbed soil areas with areas between 2 ha and 4 ha (5 ac and 10 ac).

- Limitations**
- Alternative BMPs must be thoroughly investigated for erosion control before selecting temporary desilting basins.
  - Requires large surface areas to permit settling of sediment.
  - Not appropriate for drainage areas greater than 30 ha (75 ac).
  - Not to be located in live streams

## Standards and Specifications

- For safety reasons, basins shall have protective fencing.
- Size may be limited by availability of right-of-way.
- Limit the contributing area to the sediment/desilting basin to only the runoff from the disturbed soil areas. Use temporary concentrated flow conveyance controls to divert runoff from undisturbed areas away from the sediment/desilting basin.

### **Sediment Basin**

- Sediment basins shall, at a minimum, be designed as follows:
  - Option 1: Pursuant to local ordinance for sediment basin design and maintenance, provided that the design efficiency is as protective or more protective of water quality than Option 3.

OR

- Option 2: Sediment basin(s), as measured from the bottom of the basin to the principal outlet, shall have at least a capacity equivalent to 102 cubic meters (3,600 cubic feet) of storage per 0.4 hectare (1 acre) draining into the sediment basin. The length of the basin shall be more than twice the width of the basin. The length is determined by measuring the distance between the inlet and the outlet; and the depth must not be less than 0.9 m (3 ft) nor greater than 1.5 m (5 ft) for safety reasons and for maximum efficiency.

OR

- Option 3: Sediment basin(s) shall be designed using the standard equation:

$$A_s = 1.2Q/V_s \quad (\text{Eq. 1})$$

Where:

$A_s$  = Minimum surface area for trapping soil particles of a certain size

$V_s$  = Settling velocity of the design particle size chosen

$$Q = C I A$$

Where:

$Q$  = Discharge rate measured in cubic feet per second

$C$  = Runoff coefficient

$I$  = Precipitation intensity for the 10-year, 6-hour rain event

$A$  = Area draining into the sediment basin in acres



The design particle size shall be the smallest soil grain size determined by wet sieve analysis, or the fine silt sized (0.01mm) particle, and the  $V_s$  used shall be 100 percent of the calculated settling velocity.

The length is determined by measuring the distance between the inlet and the outlet; the length shall be more than twice the dimension as the width; the depth shall not be less than 0.9 m (3 ft) nor greater than 1.5 m (5 ft) for safety reasons and for maximum efficiency [0.6 m (2 ft) of sediment storage, 0.6 m (2 ft) of capacity]. The basin(s) shall be located on the site where it can be maintained on a year-round basis and shall be maintained on a schedule to retain the 0.6 m (2 ft) of capacity.

OR

- Option 4: The use of an equivalent surface area design or equation, provided that the design efficiency is as protective or more protective of water quality than Option 3.

## ***Desilting Basin***

- Desilting basins shall be designed to have a capacity equivalent to 100 cubic meters of storage (as measured from the top of the basin to the principal outlet) per hectare of contributory area. This design is less than the required to capture the 0.01 mm particle size but larger than that required to capture particles 0.02 mm or larger.
- The length of the basin shall be more than twice the width of the basin; the length shall be determined by measuring the distance between the inlet and the outlet.
- The depth must be no less than one (1) meter nor greater than 1.5 m.
- Basins with an impounding levee greater than 1.5 m (5 ft) tall, measured from the lowest point to the impounding area to the highest point of the levee, and basins capable of impounding more than 1000 cubic meters (35,300 cubic feet), shall be designed by a professional Civil Engineer registered with the state of California. The design must be submitted to the Resident Engineer (RE) for approval at least 7 days prior to the basin construction. The design shall include maintenance requirements, including sediment and vegetation removal, to ensure continuous function of the basin outlet and bypass structures.

## ***General Requirements***

- Design and locate sediment/desilting basins so that they can be maintained. Construct desilting basins prior to the rainy season and construction activities.
- Sediment/desilting basins, regardless of size and storage volume, shall include features to accommodate overflow or bypass flows that exceed the design storm event. The calculated basin volume and proposed location shall be submitted to

the RE for approval at least 3 days prior to the basin construction.

- Construct an emergency spillway to accommodate flows not carried by the principal spillway. Spillway shall consist of an open channel (earthen or vegetated) over undisturbed material (not fill) or constructed of a non-erodible riprap.
- Spillway control section, which is a level portion of the spillway channel at the highest elevation in the channel, shall be a minimum of 6 m (20 ft) in length.
- A forebay, constructed upstream of the basin may be provided to remove debris and larger particles.
- Basin inlets shall be located to maximize travel distance to the basin outlet.
- Rock or vegetation shall be used to protect the basin inlet and slopes against erosion.
- The outflow from the basins shall be provided with outlet protection to prevent erosion and scouring of the embankment and channel. See BMP SS-10, "Outlet Protection/Velocity Dissipation Devices."
- Basin shall be located: (1) by excavating a suitable area or where a low embankment can be constructed across a swale, (2) where post-construction (permanent) detention basins will be constructed, (3) where failure would not cause loss of life or property damage, (4) where the basins can be maintained on a year-round basins to provide access for maintenance, including sediment removal and sediment stockpiling in a protected area, and to maintain the basin to provide the required capacity.
- Areas under embankments, structural works, and sediment/desilting basin must be cleared, stripped of vegetation in accordance with Standard Specifications Section 16 – "Clearing and Grubbing."
- Earthwork shall be in accordance with Standard Specifications Section 19 – "Earthwork". Contractor is specifically directed to Standard Specifications Sections 19-5, "Compaction," and 19-6, "Embankment Construction."
- Structure shall be placed on a firm, smooth foundation with the base securely anchored with concrete or other means to prevent floatation.
- Discharge from the basin shall be accomplished through a water quality outlet. An example is shown in Figure 3. The Principal outlet shall consist of a corrugated metal, high density polyethylene (HDPE), or reinforced concrete riser pipe with dewatering holes and an anti-vortex device and trash rack attached to the top of the riser, to prevent floating debris from flowing out of the basin or obstructing the system. This principal structure shall be designed

to accommodate the inflow design storm.

- A rock pile or rock-filled gabions can serve as alternatives to the debris screen, although the designer should be aware of the potential for extra maintenance involved should the pore spaces in the rock pile clog.
- Proper hydraulic design of the outlet is critical to achieving the desired performance of the basin. The water quality outlet should be designed to drain the basin within 24 to 72 hours (also referred to as “drawdown time”). (The 24-hour limit is specified to provide adequate settling time; the 72-hour limit is specified to mitigate vector control concerns.)
- The two most common outlet problems that occur are: (1) the capacity of the outlet is too great resulting in only partial filling of the basin and drawdown time less than designed for; and (2) the outlet clogs because it is not adequately protected against trash and debris. To avoid these problems, the following outlet types are recommended for use: (1) a single orifice outlet with or without the protection of a riser pipe, and (2) perforated riser. Design guidance for single orifice and perforated riser outlets are as follows:

***Flow Control Using a Single Orifice At The Bottom Of The Basin***

**(Figure 1):** The outlet control orifice should be sized using the following equation:

$$a = \frac{2A(H - Ho)^{0.5}}{3600CT(2g)^{0.5}} = \frac{(7 \times 10^{-5})A(H - Ho)^{0.5}}{CT} \quad (\text{Eq. 2})$$

where:

- $a$  = area of orifice (ft<sup>2</sup>) (1 ft<sup>2</sup> = 0.0929m<sup>2</sup>)
- $A$  = surface area of the basin at mid elevation (ft<sup>2</sup>)
- $C$  = orifice coefficient
- $T$  = drawdown time of full basin (hrs)
- $G$  = gravity (32.2 ft/s<sup>2</sup>)
- $H$  = elevation when the basin is full (ft)
- $Ho$  = final elevation when basin is empty (ft)

With a drawdown time of 40 hours, the equation becomes:

$$a = \frac{(1.75 \times 10^{-6})A(H - Ho)^{0.5}}{C} \quad (\text{Eq. 3})$$

***Flow Control Using Multiple Orifices (see Figure2):***

$$a_t = \frac{2A(h_{max})}{CT(2g[h_{max} - h_{centroid\ of\ orifices}])^{0.5}} \quad (\text{Eq. 4})$$

With terms as described above except:

$a_t$  = total area of orifices

$h_{max}$  = maximum height from lowest orifice to the maximum water surface (ft)

$h_{centroid\ of\ orifices}$  = height from the lowest orifice to the centroid of the orifice configuration (ft)

Allocate the orifices evenly on two rows; separate the holes by 3x hole diameter vertically, and by 120 degrees horizontally (refer to Figure 3).

Because basins are not maintained for infiltration, water loss by infiltration should be disregarded when designing the hydraulic capacity of the outlet structure.

Care must be taken in the selection of "C"; 0.60 is most often recommended and used. However, based on actual tests, GKY (1989), "Outlet Hydraulics of Extended Detention Facilities for Northern Virginia Planning District Commission", recommends the following:

C = 0.66 for thin materials; where the thickness is equal to or less than the orifice diameter, or

C = 0.80 when the material is thicker than the orifice diameter

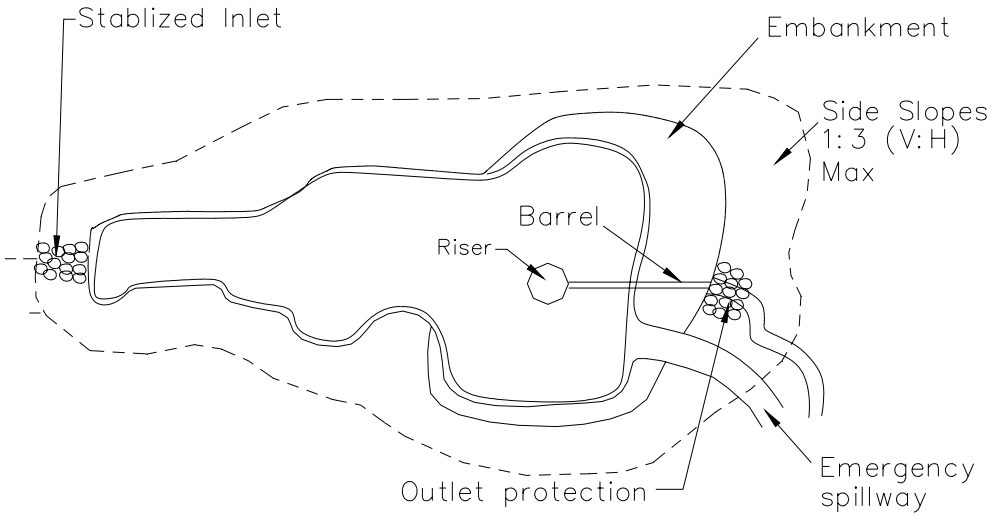
- The Contractor shall verify that the outlet is properly designed to handle the design and peak flows.
- Attach riser pipe (watertight connection) to a horizontal pipe (barrel), which extends through the embankment to toe of fill. Provide anti-seep collars on the barrel.
- Cleanout level shall be clearly marked on the riser pipe
- Avoid dewatering of groundwater to the sediment/desilting basin during the rainy season. Insignificant quantities of accumulated precipitation may be dewatered to the sediment/desilting basin unless precipitation is forecasted within 24 hours. Refer to NS-2 "Dewatering Operations."
- Chain link fencing shall be provided around each sediment/desilting basin to prevent unauthorized entry to the basin or if safety is a concern. Fencing shall be in accordance with Standard Specifications Section 80 – "Fencing."

## Maintenance and Inspection

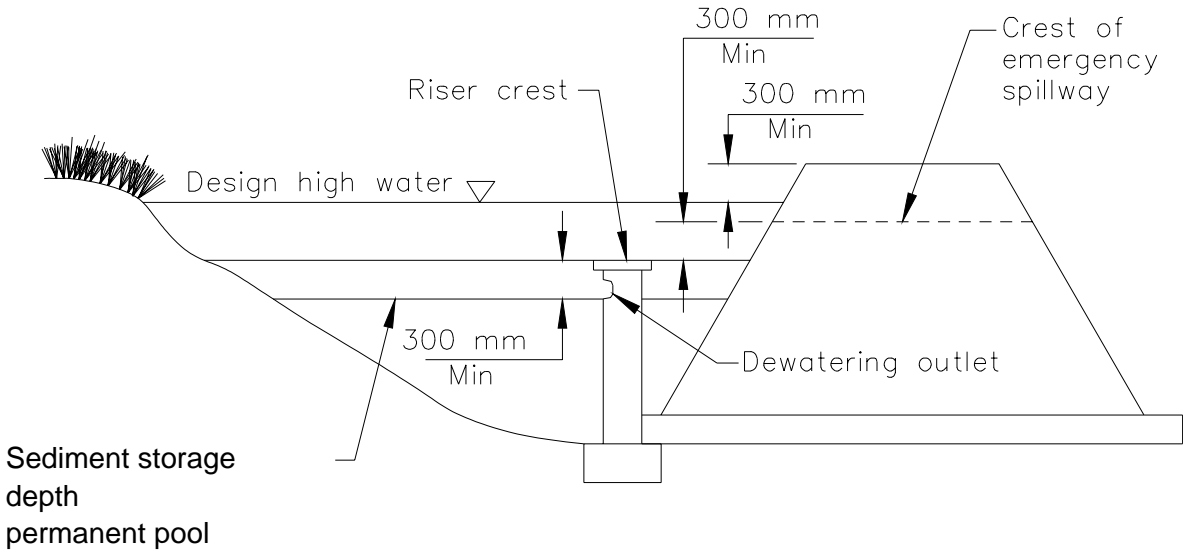
- Inspect sediment/desilting basins before and after rainfall events and weekly during the rest of the rainy season. During extended rainfall events, inspect at

least every 24 hours.

- Examine basin banks for seepage and structural soundness.
- Check inlet and outlet structures and spillway for any damage or obstructions. Repair damage and remove obstructions as needed, or as directed by the RE.
- Remove standing water from the basin within 72 hours after accumulation.
- Check inlet and outlet area for erosion and stabilize if required, or if directed by the RE.
- Remove accumulated sediment when its volume reaches one-third the volume of the sediment storage. Properly dispose of sediment and debris removed from the basin.
- Check fencing for damage and repair as needed or as directed by the RE.

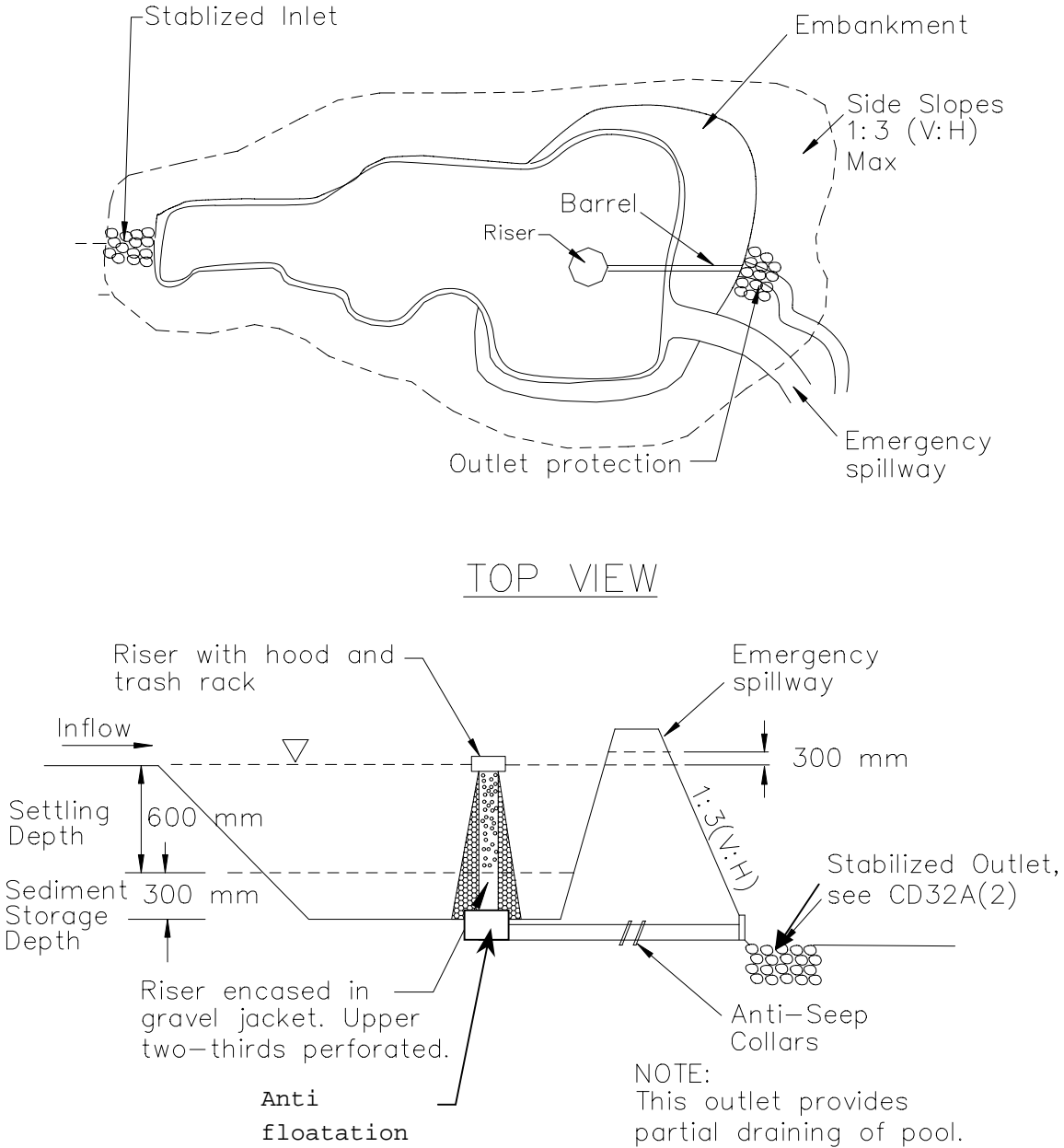


TOP VIEW



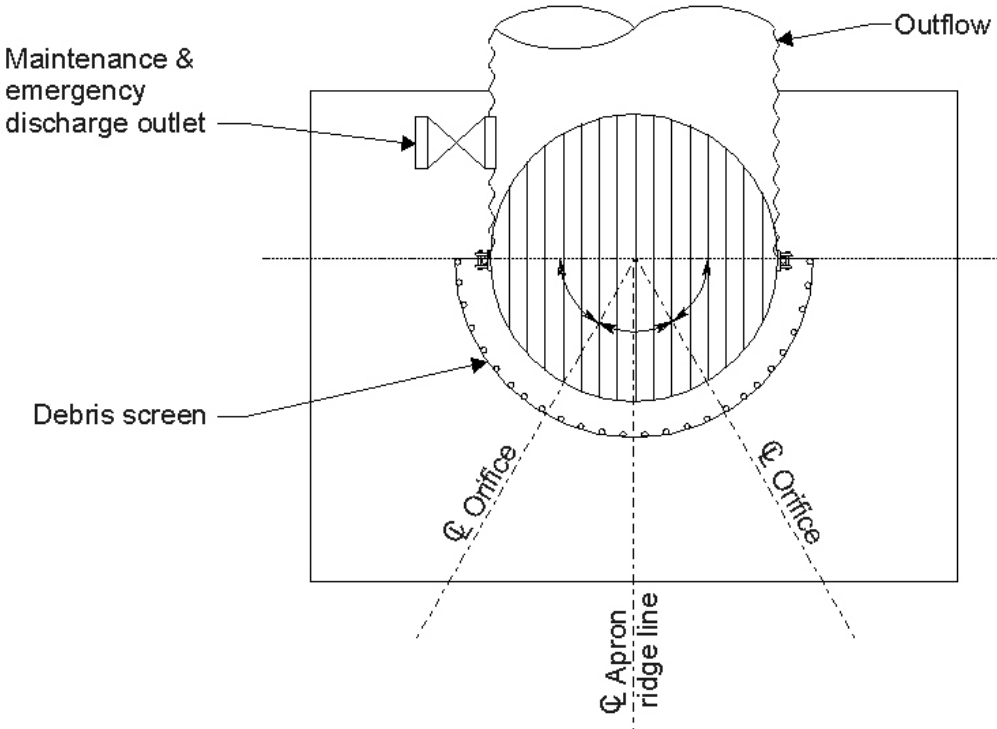
This outlet provides no drainage for permanent pool.

**FIGURE 1: SINGLE ORIFICE DESIGN**  
NOT TO SCALE

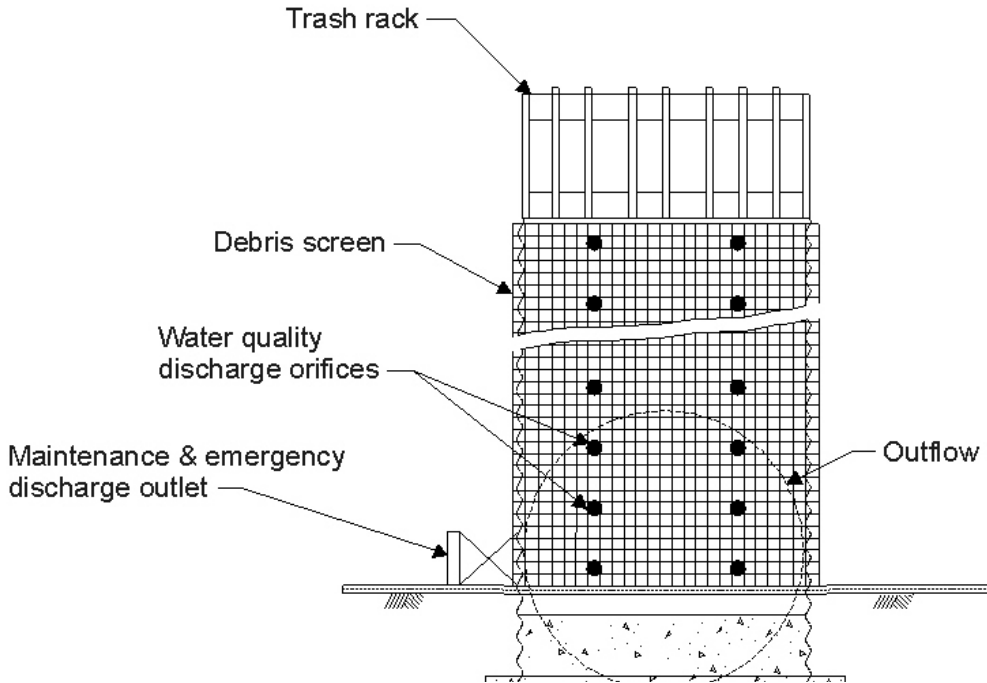


**FIGURE 2: MULTIPLE ORIFICE DESIGN**  
**NOT TO SCALE**

### Plan

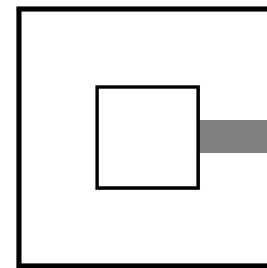
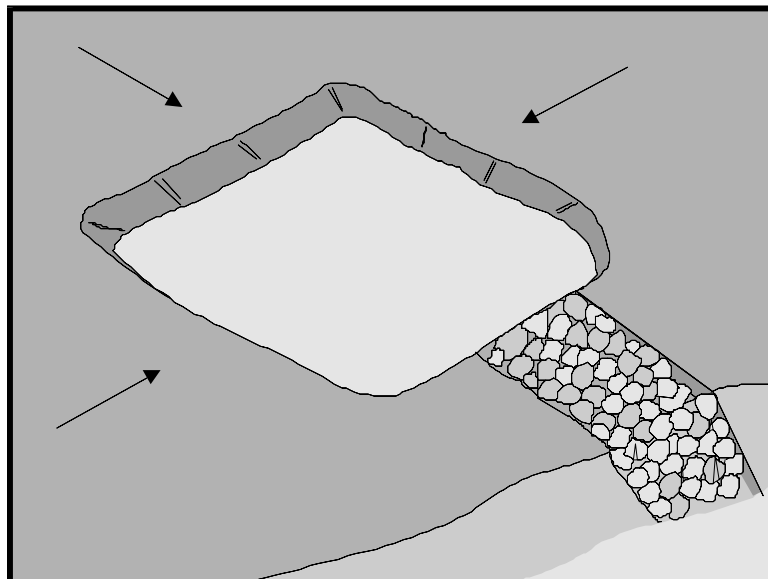


### Profile



**FIGURE 3: MULTIPLE ORIFICE OUTLET RISER**  
**NOT TO SCALE**





Standard Symbol

### BMP Objectives

- Soil Stabilization
- Sediment Control
- Tracking Control
- Wind Erosion Control
- Non-Storm Water Management
- Materials and Waste Management

**Definition and Purpose** A sediment trap is a temporary containment area that allows sediment in collected storm water to settle out during infiltration or before the runoff is discharged through a stabilized spillway. Sediment traps are formed by excavating or constructing an earthen embankment across a waterway or low drainage area.

- Appropriate Applications**
- Sediment traps may be used on construction projects where the drainage area is less than 2 ha (5 ac). Traps should be placed where sediment-laden storm water enters a storm drain or watercourse.
  - This BMP may be implemented on a project-by-project basis with other BMPs when determined necessary and feasible by the Resident Engineer (RE).
  - As a supplemental control, sediment traps provide additional protection for a water body or for reducing sediment before it enters a drainage system.

- Limitations**
- Requires large surface areas to permit infiltration and settling of sediment.
  - Not appropriate for drainage areas greater than 2 ha (5 ac).
  - Only removes large and medium sized particles and requires upstream erosion control.
  - Attractive and dangerous to children, requiring protective fencing.
  - Not to be located in live streams.
  - Size may be limited by availability of right-of-way.

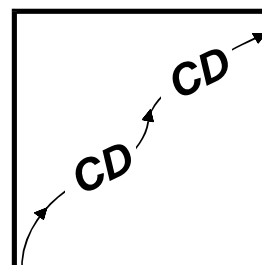
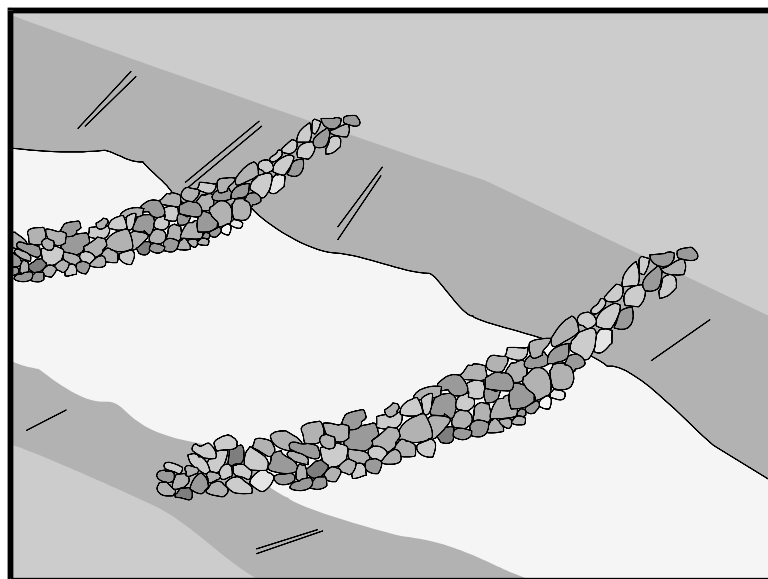
## Standards and Specifications

- Construct sediment traps prior to rainy season and construction activities.
- Trap shall be situated according to the following criteria: (1) by excavating a suitable area or where a low embankment can be constructed across a swale, (2) where failure would not cause loss of life or property damage, and (3) to provide access for maintenance, including sediment removal and sediment stockpiling in a protected area.
- Trap shall be sized to accommodate a settling zone and sediment storage zone with recommended minimum volumes of 130 m<sup>3</sup>/ha (67 yd<sup>3</sup>/ac) and 65 m<sup>3</sup>/ha (33 yd<sup>3</sup>/ac) of contributing drainage area, respectively, based on 12.7 mm (0.5 in) of runoff volume over a 24-hr period. Multiple traps and/or additional volume may be required to accommodate site specific rainfall and soil conditions.
- Traps with an impounding levee greater than 1.5 m (5 ft) tall, measured from the lowest point to the impounding area to the highest point of the levee, and traps capable of impounding more than 1000 cubic meters (35,300 cubic feet), shall be designed by a professional Civil Engineer registered with the state of California. The design must be submitted to the Resident Engineer (RE) for approval at least 7 days prior to the basin construction. The design shall include maintenance requirements, including sediment and vegetation removal, to ensure continuous function of the trap outlet and bypass structures.
- Earthwork shall be in accordance with Standard Specifications Section 19 – “Earthwork”. Contractor is specifically directed to Standard Specifications Sections 19-5 and 19-6 entitled, “Compaction” and “Embankment Construction,” respectively.
- Areas under embankments, structural works, and sediment traps shall be cleared and stripped of vegetation in accordance with Standard Specifications Section 16 – “Clearing and Grubbing.”
- Use rock or vegetation to protect the trap outlets against erosion.
- Fencing, in accordance with Standard Specifications Section 80 – “Fencing,” shall be provided to prevent unauthorized entry.

## Maintenance and Inspection

- Inspect sediment traps before and after rainfall events and weekly during the rest of the rainy season. During extended rainfall events, inspect sediment traps at least every 24 hours.
- If captured runoff has not completely infiltrated within 72 hours then the sediment trap must be dewatered.
- Inspect trap banks for embankment seepage and structural soundness.

- Inspect outlet structure and rock spillway for any damage or obstructions. Repair damage and remove obstructions as needed or as directed by the RE.
- Inspect outlet area for erosion and stabilize if required, or as directed by the RE.
- Remove accumulated sediment when the volume has reached one-third the original trap volume.
- Properly disposed of sediment and debris removed from the trap.
- Inspect fencing for damage and repair as needed or as directed by the RE.



Standard Symbol

- BMP Objectives**
- Soil Stabilization
  - Sediment Control
  - Tracking Control
  - Wind Erosion Control
  - Non-Storm Water Management
  - Materials and Waste Management

**Definition and Purpose** Check dams reduce scour and channel erosion by reducing flow velocity and encouraging sediment settlement. A check dam is a small device constructed of rock, gravel bags, sandbags, fiber rolls, or other proprietary product placed across a natural or man-made channel or drainage ditch.

- Appropriate Applications**
- Check dams may be installed:
    - In small open channels that drain 4 ha (10 ac) or less.
    - In steep channels where storm water runoff velocities exceed 1.5 m/s (4.9 ft/sec).
    - During the establishment of grass linings in drainage ditches or channels.
    - In temporary ditches where the short length of service does not warrant establishment of erosion-resistant linings.
  - This BMP may be implemented on a project-by-project basis with other BMPs when determined necessary and feasible by the Resident Engineer (RE).

- Limitations**
- Not to be used in live streams.
  - Not appropriate in channels that drain areas greater than 4 ha (10 ac).
  - Not to be placed in channels that are already grass lined unless erosion is expected, as installation may damage vegetation.
  - Require extensive maintenance following high velocity flows.
  - Promotes sediment trapping, which can be re-suspended during subsequent storms or removal of the check dam.

## Standards and Specifications

- Not to be constructed from straw bales or silt fence.
- Check dams shall be placed at a distance and height to allow small pools to form behind them. Install the first check dam approximately 5 meters (16 ft) from the outfall device and at regular intervals based on slope gradient and soil type.
- For multiple check dam installation, backwater from downstream check dam shall reach the toe of the upstream dam.
- High flows (typically a 2-year storm or larger) shall safely flow over the check dam without an increase in upstream flooding or damage to the check dam.
- Where grass is used to line ditches, check dams shall be removed when grass has matured sufficiently to protect the ditch or swale.
- Rock shall be placed individually by hand or by mechanical methods (no dumping of rock) to achieve complete ditch or swale coverage.
- Fiber rolls may be used as check dams if approved by the RE or the Construction NPDES Coordinator. Refer to SC-5 “Fiber Rolls.”
- Gravel bags may be used as check dams with the following specifications:

### **Materials**

- **Bag Material:** Bags shall be either polypropylene, polyethylene or polyamide woven fabric, minimum unit weight 135 g/m<sup>2</sup> (four ounces per square yard), mullen burst strength exceeding 2,070 kPa (300 psi) in conformance with the requirements in ASTM designation D3786, and ultraviolet stability exceeding 70% in conformance with the requirements in ASTM designation D4355.
- **Bag Size:** Each gravel-filled bag shall have a length of 450 mm (18 in), width of 300 mm (12 in), thickness of 75 mm (3 in), and mass of approximately 15 kg (33 lb). Bag dimensions are nominal, and may vary based on locally available materials. Alternative bag sizes shall be submitted to the RE for approval prior to deployment.
- **Fill Material:** Fill material shall be between 10 mm and 20 mm (0.4 and 0.8 inch) in diameter, and shall be clean and free from clay balls, organic matter, and other deleterious materials. The opening of gravel-filled bags shall be secured such that gravel does not escape. Gravel-filled bags shall be between 13 kg and 22 kg (28 and 48 lb) in mass. Fill material is subject to approval by the RE.

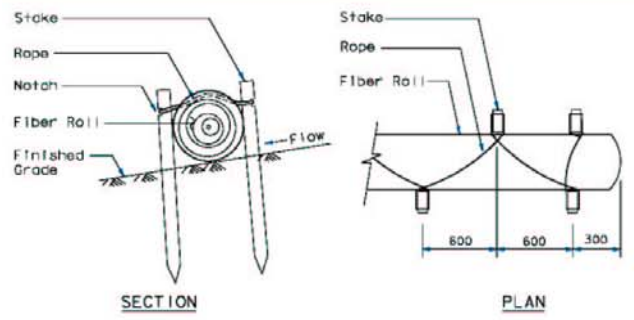
### **Installation**

- Install along a level contour.
- Tightly abut bags and stack gravel bags using a pyramid approach.

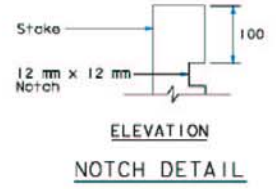
Gravel bags shall not be stacked any higher than 1 meter (3.2 ft).

- Upper rows of gravel bags shall overlap joints in lower rows.
- **Maintenance and Inspection** ■ Inspect check dams after each significant rainfall event. Repair damage as needed or as required by the RE.
- Remove sediment when depth reaches one-third of the check dam height.
- Remove accumulated sediment prior to permanent seeding or soil stabilization.
- Remove check dam and accumulated sediment when check dams are no longer needed or when required by the RE.
- Removed sediment shall be incorporated in the project at locations designated by the RE or disposed of outside the highway right-of-way in conformance with the Standard Specifications.

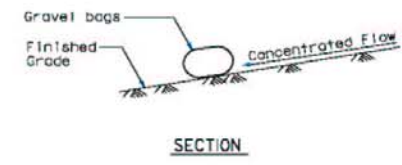
# Check Dams



**STAKING AND LASHING DETAIL**

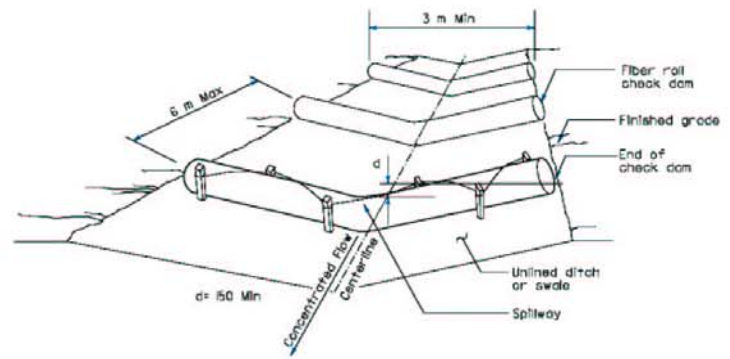


**NOTCH DETAIL**

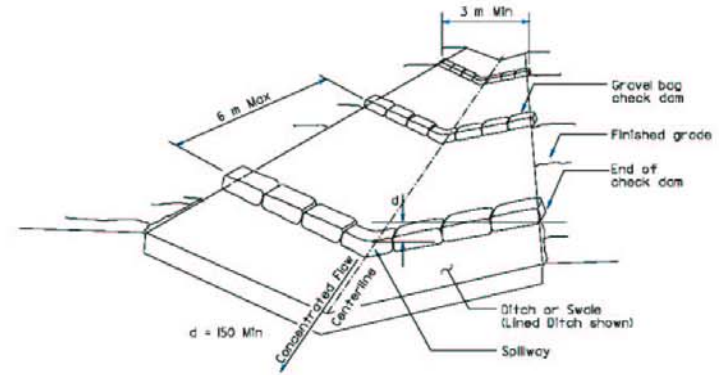


**TEMPORARY CHECK DAM (TYPE 2)**

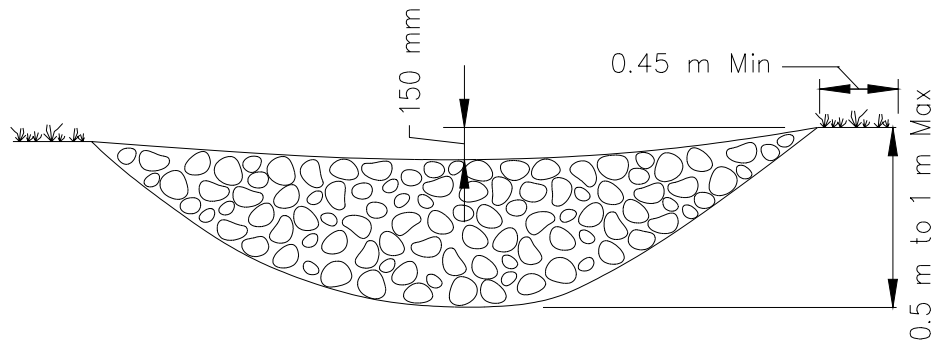
**NOTE**  
1. Spillway depth 'd' shall be maintained to prevent flanking of concentrated flow around the ends of check dam.



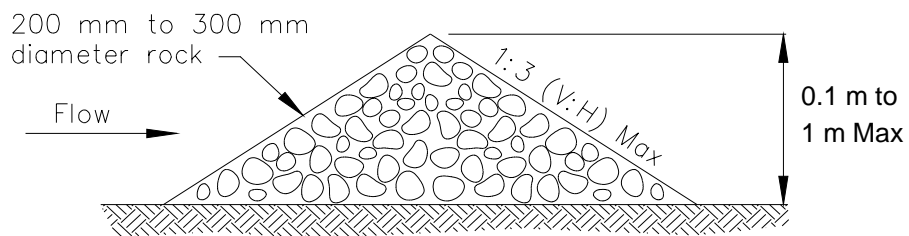
**PERSPECTIVE  
TEMPORARY CHECK DAM (TYPE 1)**



**PERSPECTIVE  
TEMPORARY CHECK DAM (TYPE 2)**



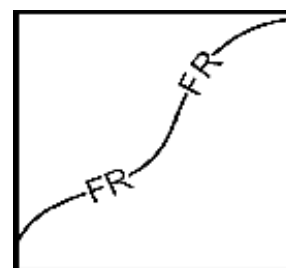
ELEVATION



TYPICAL ROCK CHECK DAM SECTION

ROCK CHECK DAM  
NOT TO SCALE





Standard Symbol

### BMP Objectives

- Soil Stabilization
- Sediment Control
- Tracking Control
- Wind Erosion Control
- Non-Storm Water Management
- Materials and Waste Management

**Definition and Purpose** A fiber roll consists of wood excelsior, rice or wheat straw, or coconut fibers that is rolled or bound into a tight tubular roll and placed on the toe and face of slopes to intercept runoff, reduce its flow velocity, release the runoff as sheet flow and provide removal of sediment from the runoff. Fiber rolls may also be used for inlet protection and as check dams under certain situations.

- Appropriate Applications**
- This BMP may be implemented on a project-by-project basis with other BMPs when determined necessary and feasible by the RE.
  - Along the toe, top, face, and at grade breaks of exposed and erodible slopes to shorten slope length and spread runoff as sheet flow.
  - Below the toe of exposed and erodible slopes.
  - Fiber rolls may be used as check dams in unlined ditches if approved by the Resident Engineer (RE) or the District Construction Storm Water Coordinator (refer to SC-4 “Check Dams”).
  - Fiber rolls may be used for drain inlet protection if approved by the RE or the District Construction Storm Water Coordinator (refer to SC-10 “Storm Drain Inlet Protection”).
  - Down-slope of exposed soil areas.
  - Around temporary stockpiles.
  - Along the perimeter of a project.

- Limitations**
- Runoff and erosion may occur if fiber roll is not adequately trenched in.
  - Fiber rolls at the toe of slopes greater than 1:5 may require the use of 500 mm (20" diameter) or installations achieving the same protection (i.e., stacked smaller diameter fiber rolls, etc.).
  - Fiber rolls may be used for drainage inlet protection if they can be properly anchored.
  - Difficult to move once saturated.
  - Fiber rolls could be transported by high flows if not properly staked and trenched in.
  - Fiber rolls have limited sediment capture zone.
  - Do not use fiber rolls on slopes subject to creep, slumping, or landslide.

**Standards and Specifications**

***Fiber Roll Materials***

- Fiber rolls shall be either:
  - (1) Prefabricated rolls.
  - (2) Rolled tubes of erosion control blanket.

***Assembly of Field Rolled Fiber Roll***

- Roll length of erosion control blanket into a tube of minimum 200 mm (8 in) diameter.
- Bind roll at each end and every 1.2 m (4 ft) along length of roll with jute-type twine.

***Installation***

- Slope inclination of 1:4 or flatter: fiber rolls shall be placed on slopes 6.0 m apart.
- Slope inclination of 1:4 to 1:2: fiber rolls shall be placed on slopes 4.5 m apart.
- Slope inclination 1:2 or greater: fiber rolls shall be placed on slopes 3.0 m apart.
- Stake fiber rolls into a 50 to 100 mm (2 to 4 in) trench.

- Drive stakes at the end of each fiber roll and spaced 600 mm (2 ft) apart if Type 2 installation is used (refer to Page 4). Otherwise, space stakes 1.2 m (4 ft) maximum on center if installed as shown on Pages 5 and 6.
- Use wood stakes with a nominal classification of 19 by 19 mm (3/4 by 3/4 in), and minimum length of 600 mm (24 in).
- If more than one fiber roll is placed in a row, the rolls shall be overlapped; not abutted.

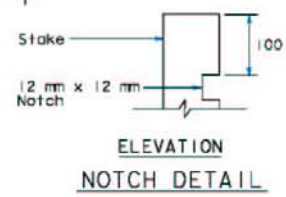
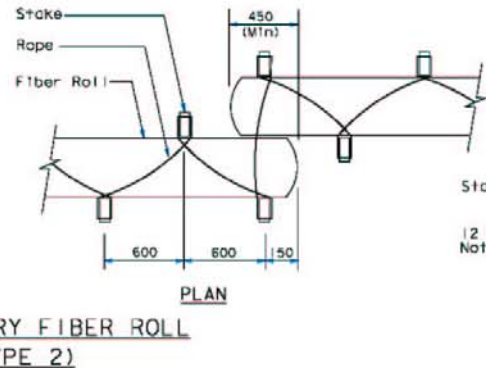
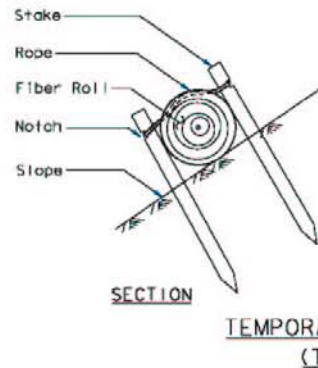
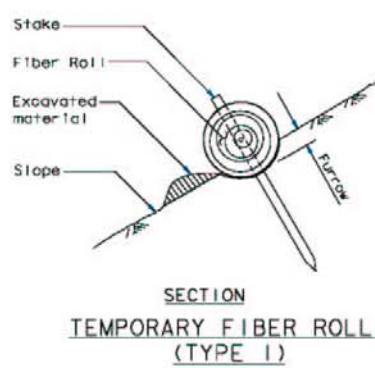
### **Removal**

- Fiber rolls are typically left in place.
- If fiber rolls are removed, collect and dispose of sediment accumulation, and fill and compact holes, trenches, depressions or any other ground disturbance to blend with adjacent ground.

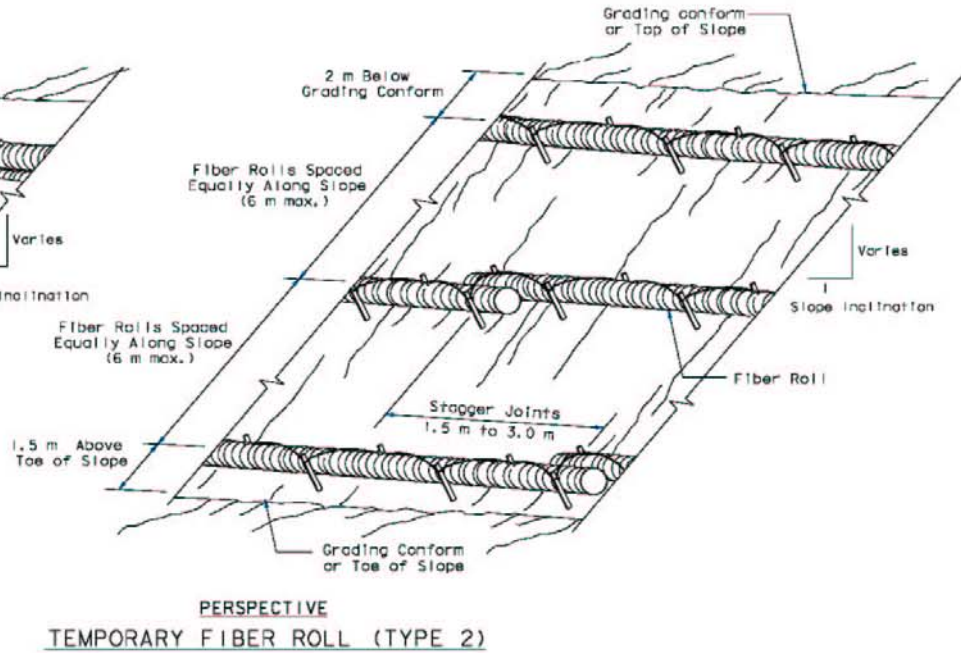
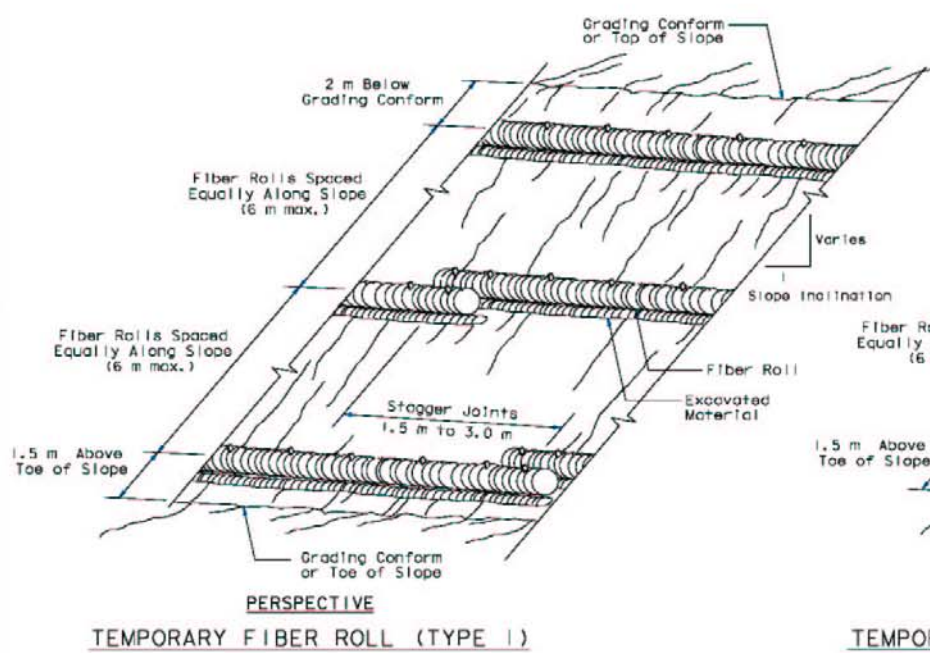
### **Maintenance and Inspection**

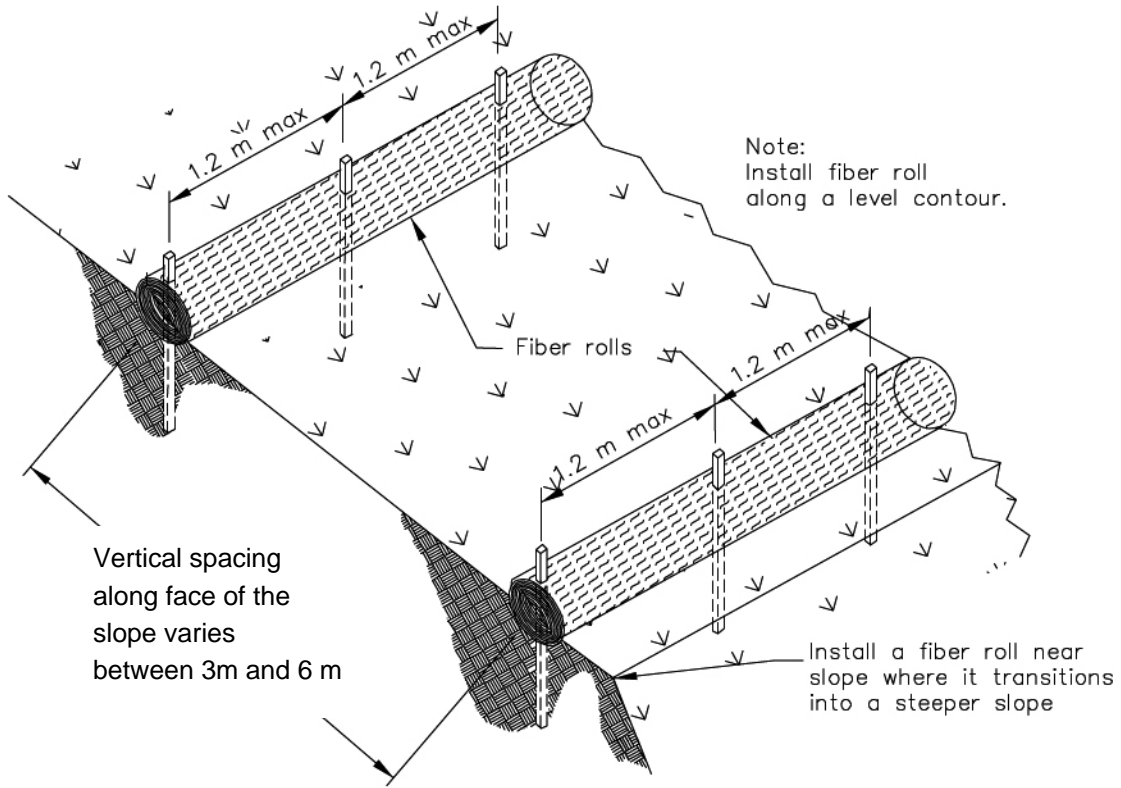
- Repair or replace split, torn, unraveling, or slumping fiber rolls.
- Inspect fiber rolls when rain is forecast. Perform maintenance as needed or as required by the RE.
- Inspect fiber rolls following rainfall events and at least daily during prolonged rainfall. Perform maintenance as needed or as required by the RE.
- Maintain fiber rolls to provide an adequate sediment holding capacity. Sediment shall be removed when the sediment accumulation reaches three quarters (3/4) of the barrier height. Removed sediment shall be incorporated in the project at locations designated by the RE or disposed of outside the highway right-of-way in conformance with the Standard Specifications.

# Fiber Rolls

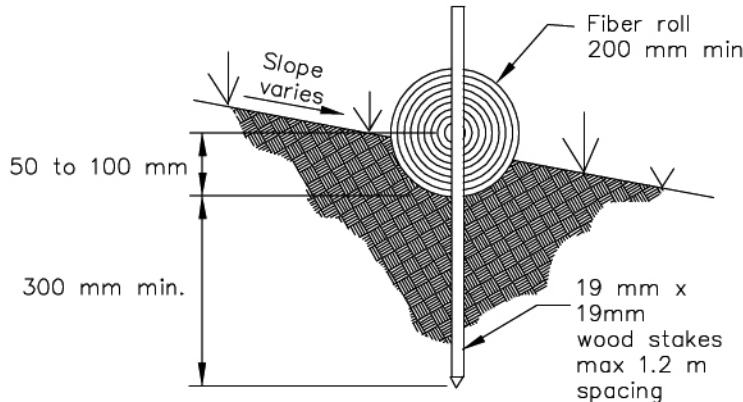


NOTE  
1. Temporary fiber roll spacing varies depending upon slope inclination.

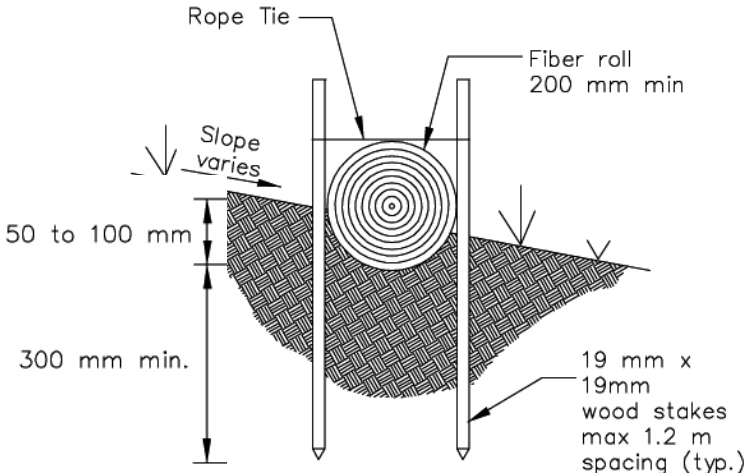
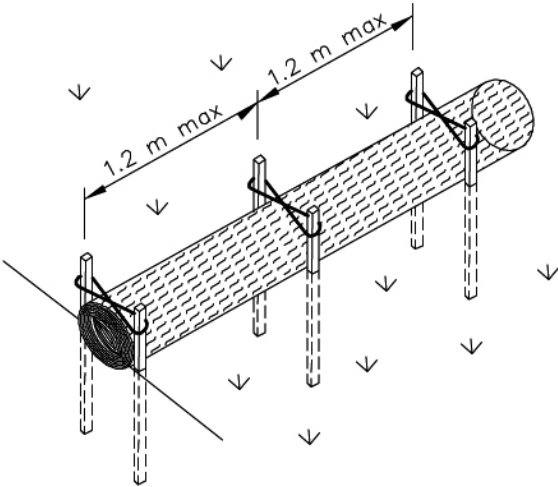




TYPICAL FIBER ROLL INSTALLATION  
N.T.S.

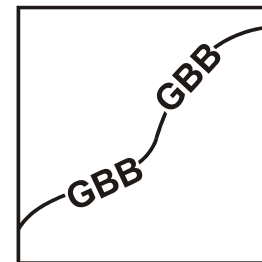
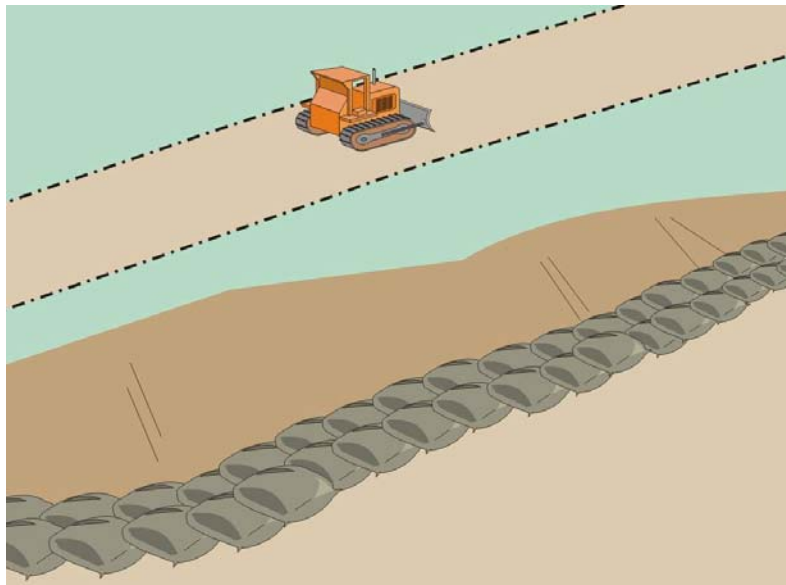


ENTRENCHMENT DETAIL  
N.T.S.



OPTIONAL ENTRENCHMENT DETAIL

N.T.S.



Standard Symbol

**BMP Objectives**

- Soil Stabilization
- Sediment Control
- Tracking Control
- Wind Erosion Control
- Non-Storm Water Management
- Materials and Waste Management

**Definition and Purpose** A gravel bag berm consists of a single row of gravel bags that are installed end to end to form a barrier across a slope to intercept runoff, reduce its flow velocity, release the runoff as sheet flow and provide some sediment removal. Gravel bags can be used where flows are moderately concentrated, such as ditches, swales, and storm drain inlets (see BMP SC-10, Storm Drain Inlet Protection) to divert and/or detain flows.

- Appropriate Applications**
- BMP may be implemented on a project-by-project basis with other BMPs when determined necessary and feasible by the RE.
  - Along streams and channels.
  - Below the toe of exposed and erodible slopes.
  - Down slope of exposed soil areas.
  - Around stockpiles.
  - Across channels to serve as a barrier for utility trenches or provide a temporary channel crossing for construction equipment, to reduce stream impacts.
  - Parallel to a roadway to keep sediment off paved areas.
  - At the top of slopes to divert roadway runoff away from disturbed slopes.
  - Along the perimeter of a site.
  - To divert or direct flow or create a temporary sediment basin.
  - During construction activities in stream beds when the contributing drainage

area is less than 2 ha (5 ac).

- When extended construction period limits the use of either silt fences or straw bale barriers.
- When site conditions or construction sequencing require adjustments or relocation of the barrier to meet changing field conditions and needs during construction.
- At grade breaks of exposed and erodible slopes to shorten slope length and spread runoff as sheet flow.

## Limitations

- Degraded gravel bags may rupture when removed, spilling contents.
- Installation can be labor intensive.
- Limited durability for long term projects.
- When used to detain concentrated flows, maintenance requirements increase.

## Standards and Specifications

### **Materials**

- **Bag Material:** Bags shall be woven polypropylene, polyethylene or polyamide fabric, minimum unit weight 135 g/m<sup>2</sup> (four ounces per square yard), mullen burst strength exceeding 2,070 kPa (300 psi) in conformance with the requirements in ASTM designation D3786, and ultraviolet stability exceeding 70% in conformance with the requirements in ASTM designation D4355.
- **Bag Size:** Each gravel-filled bag shall have a length of 450 mm (18 in), width of 300 mm (12 in), thickness of 75 mm (3 in), and mass of approximately 15 kg (33 lb). Bag dimensions are nominal, and may vary based on locally available materials. Alternative bag sizes shall be submitted to the RE for approval prior to deployment.
- **Fill Material:** Gravel shall be between 10 mm and 20 mm (0.4 and 0.8 inch) in diameter, and shall be clean and free from clay balls, organic matter, and other deleterious materials. The opening of gravel-filled bags shall be between 13 kg and 22 kg (28 and 48 lb) in mass. Fill material is subject to approval by the RE.

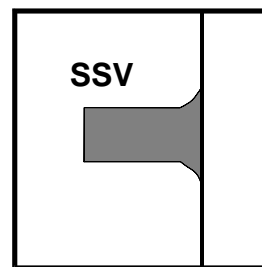
### **Installation**

- When used as a linear control for sediment removal:
  - Install along a level contour.
  - Turn ends of gravel bag row up slope to prevent flow around the ends.
  - Generally, gravel bag barriers shall be used in conjunction with temporary soil stabilization controls up slope to provide effective erosion and sediment



control.

- When used for concentrated flows:
    - Stack gravel bags to required height using a pyramid approach.
    - Upper rows of gravel bags shall overlap joints in lower rows.
  - Construct gravel bag barriers with a set-back of at least 1m from the toe of a slope. Where it is determined to be not practicable due to specific site conditions, the gravel bag barrier may be constructed at the toe of the slope, but shall be constructed as far from the toe of the slope as practicable.
  - Requires Certificate of Compliance per Standard Specifications 6-1.07.
- Maintenance and Inspection
- Inspect gravel bag berms before and after each rainfall event, and weekly throughout the rainy season.
  - Reshape or replace gravel bags as needed, or as directed by the RE.
  - Repair washouts or other damages as needed, or as directed by the RE.
  - Inspect gravel bag berms for sediment accumulations and remove sediments when accumulation reaches one-third of the berm height. Removed sediment shall be incorporated in the project at locations designated by the RE or disposed of outside the highway right-of-way in conformance with the Standard Specifications.
  - Remove gravel bag berms when no longer needed. Remove sediment accumulations and clean, re-grade, and stabilize the area.



Standard Symbol

- BMP Objectives**

  - Soil Stabilization
  - Sediment Control
  - Tracking Control
  - Wind Erosion Control
  - Non-Storm Water Management
  - Materials and Waste Management

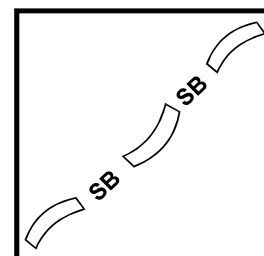
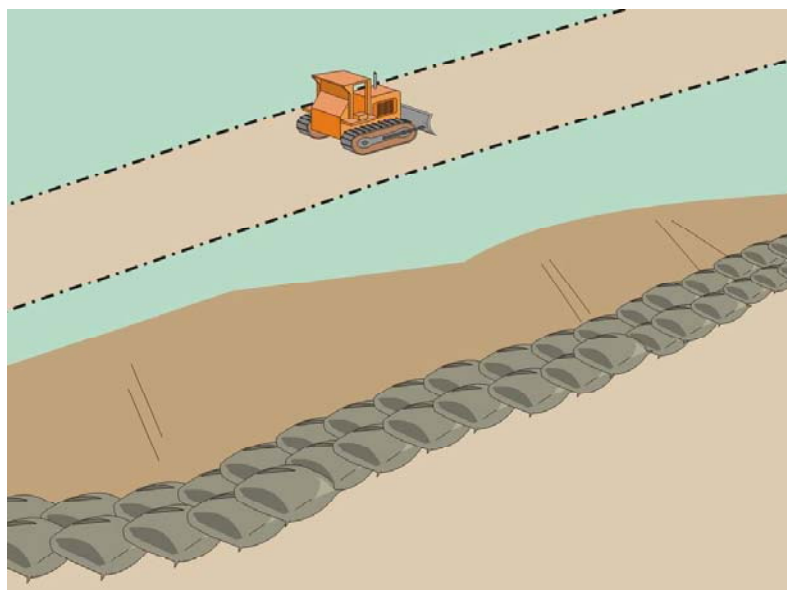
**Definition and Purpose** Practices to remove tracked sediment to prevent the sediment from entering a storm drain or watercourse.

**Appropriate Applications** These practices are implemented anywhere sediment is tracked from the project site onto public or private paved roads, typically at points of ingress/egress.

**Limitations** Sweeping and vacuuming may not be effective when soil is wet or muddy.

- Standards and Specifications**
- Kick brooms or sweeper attachments shall not be used.
  - Inspect potential sediment tracking locations daily.
  - Visible sediment tracking shall be swept and/or vacuumed daily.
  - If not mixed with debris or trash, consider incorporating the removed sediment back into the project.

- Maintenance and Inspection**
- Inspect ingress/egress access points daily and sweep tracked sediment as needed, or as required by the Resident Engineer (RE).
  - Be careful not to sweep up any unknown substance or any object that may be potentially hazardous.
  - Adjust brooms frequently; maximize efficiency of sweeping operations.
  - After sweeping is finished, properly dispose of sweeper wastes at an approved dumpsite in conformance with the provisions in Standard Specifications Section 7-1.13 .



Standard Symbol

### BMP Objectives

- Soil Stabilization
- Sediment Control
- Tracking Control
- Wind Erosion Control
- Non-Storm Water Management
- Materials and Waste Management

**Definition and Purpose** A sandbag barrier is a temporary linear sediment barrier consisting of stacked sandbags, designed to intercept and slow the flow of sediment-laden sheet flow runoff. Sandbag barriers allow sediment to settle from runoff before water leaves the construction site.

- Appropriate Applications**
- This BMP may be implemented on a project-by-project basis in addition to other BMPs when determined necessary and feasible by the Resident Engineer (RE).
  - Along the perimeter of a site.
  - Along streams and channels.
  - Below the toe of exposed and erodible slopes.
  - Down slope of exposed soil areas.
  - Around stockpiles.
  - Across channels to serve as a barrier for utility trenches or provide a temporary channel crossing for construction equipment, to reduce stream impacts.
  - Parallel to a roadway to keep sediment off paved areas.
  - At the top of slopes to divert roadway runoff away from disturbed slopes.
  - To divert or direct flow or create a temporary sediment/desilting basin.
  - During construction activities in stream beds when the contributing drainage area is less than 2 ha (5 ac).

- Appropriate Applications**
- This BMP may be implemented on a project-by-project basis in addition to other BMPs when determined necessary and feasible by the Resident Engineer (RE).
  - Along the perimeter of a site.
  - Along streams and channels.
  - Below the toe of exposed and erodible slopes.
  - Down slope of exposed soil areas.
  - Around stockpiles.
  - Across channels to serve as a barrier for utility trenches or provide a temporary channel crossing for construction equipment, to reduce stream impacts.
  - Parallel to a roadway to keep sediment off paved areas.
  - At the top of slopes to divert roadway runoff away from disturbed slopes.
  - To divert or direct flow or create a temporary sediment/desilting basin.
  - During construction activities in stream beds when the contributing drainage area is less than 2 ha (5 ac).
  - When extended construction period limits the use of either silt fences or straw bale barriers.
  - Along the perimeter of vehicle and equipment fueling and maintenance areas or chemical storage areas.
  - To capture and detain non-storm water flows until proper cleaning operations occur.
  - When site conditions or construction sequencing require adjustments or relocation of the barrier to meet changing field conditions and needs during construction.
  - To temporarily close or continue broken, damaged or incomplete curbs.
- Limitations**
- Limit the drainage area upstream of the barrier to 2 ha (5 ac).
  - Degraded sandbags may rupture when removed, spilling sand.
  - Installation can be labor intensive.
  - Limited durability for long-term projects.

- When used to detain concentrated flows, maintenance requirements increase.

## Standards and Specifications

### **Materials**

- **Sandbag Material:** Sandbag shall be woven polypropylene, polyethylene or polyamide fabric, minimum unit weight 135 g/m<sup>2</sup> (four ounces per square yard), mullen burst strength exceeding 2,070 kPa (300 psi) in conformance with the requirements in ASTM designation D3786, and ultraviolet stability exceeding 70% in conformance with the requirements in ASTM designation D4355. Use of burlap is not acceptable.
- **Sandbag Size:** Each sand-filled bag shall have a length of 450 mm (18 in), width of 300 mm (12 in), thickness of 75 mm (3 in), and mass of approximately 15 kg (33 lb.). Bag dimensions are nominal, and may vary based on locally available materials. Alternative bag sizes shall be submitted to the RE for approval prior to deployment.
- **Fill Material:** All sandbag fill material shall be non-cohesive, Class 1 or Class 2 permeable material free from clay and deleterious material, conforming to the provisions in Standard Specifications Section 68-1.025 "Permeable Material". The requirements for the Durability Index and Sand Equivalent do not apply. Fill material is subject to approval by the RE.

### **Installation**

- When used as a linear sediment control:
  - Install along a level contour.
  - Turn ends of sandbag row up slope to prevent flow around the ends.
  - Generally, sandbag barriers shall be used in conjunction with temporary soil stabilization controls up slope to provide effective erosion and sediment control.
  - Install as shown in Pages 4 and 5 of this BMP.
- Construct sandbag barriers with a set-back of at least 1m (3 ft) from the toe of a slope. Where it is determined to be not practical due to specific site conditions, the sandbag barrier may be constructed at the toe of the slope, but shall be constructed as far from the toe of the slope as practicable.

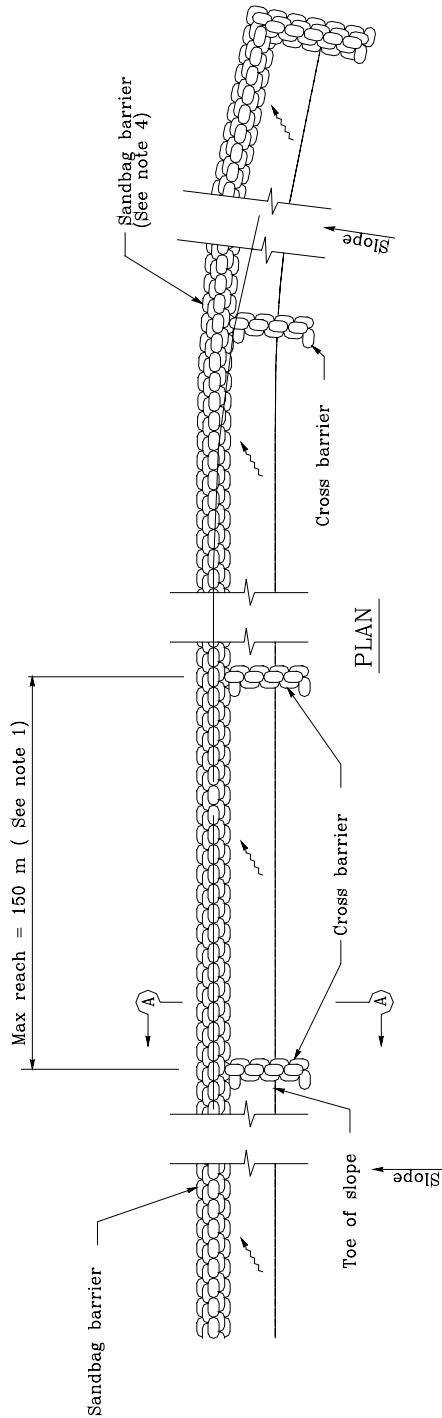
## Maintenance and Inspection

- Inspect sandbag barriers before and after each rainfall event, and weekly throughout the rainy season.

- Reshape or replace sandbags as needed, or as directed by the RE.
- Repair washouts or other damages as needed, or as directed by the RE.
- Inspect sandbag barriers for sediment accumulations and remove sediments when accumulation reaches one-third the barrier height. Removed sediment shall be incorporated in the project at locations designated by the RE or disposed of outside the highway right-of-way in conformance with the Standard Specifications.
- Remove sandbags when no longer needed. Remove sediment accumulation, and clean, re-grade, and stabilized the area.

# Sandbag Barrier

SC-8



TEMPORARY LINEAR SEDIMENT BARRIER (TYPE SANDBAG)



STATE OF CALIFORNIA  
DEPARTMENT OF TRANSPORTATION

## TEMPORARY LINEAR SEDIMENT BARRIER (TYPE SANDBAG)

NO SCALE

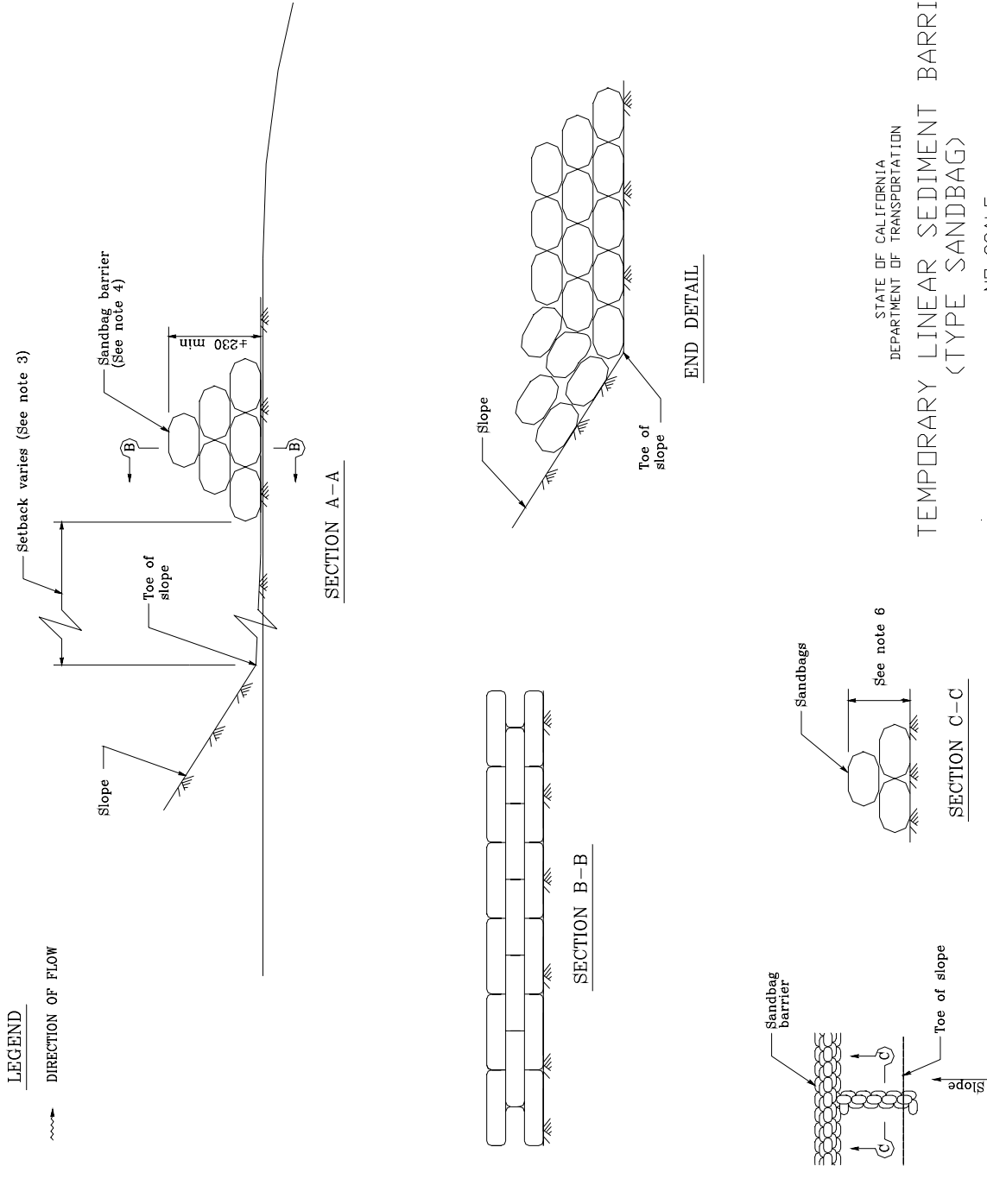
ALL DIMENSIONS ARE IN  
MILLIMETERS UNLESS OTHERWISE SHOWN

### NOTES

1. Construct the length of each reach so that the change in base elevation along the reach does not exceed 1/2 the height of the linear barrier. In no case shall the reach length exceed 150 m.
2. Place sandbags tightly.
3. Dimension may vary to fit field condition.
4. Sandbag barrier shall be a minimum of 3 bags high.
5. The end of the barrier shall be turned up slope.
6. Cross barriers shall be a min of 1/2 and a max of 2/3 the height of the linear barrier.
7. Sandbag rows and layers shall be staggered to eliminate gaps.

# Sandbag Barrier

SC-8



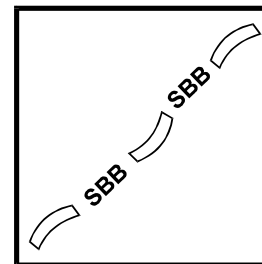
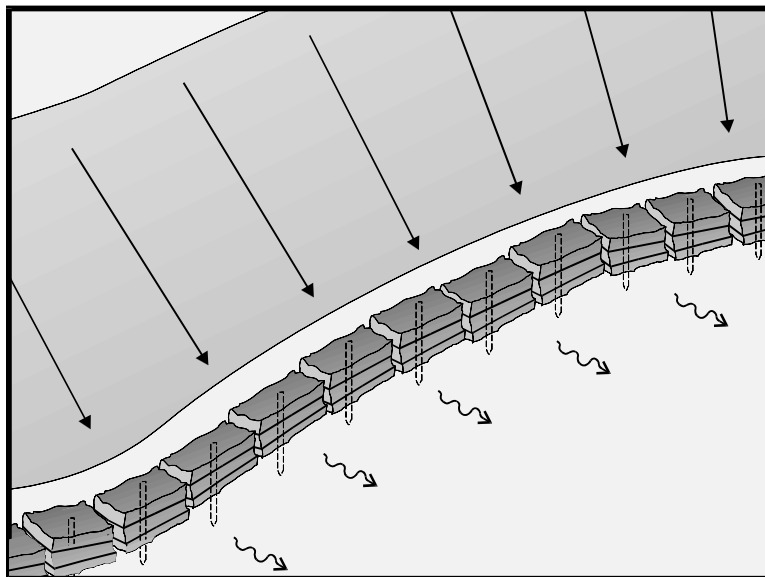
STATE OF CALIFORNIA  
 DEPARTMENT OF TRANSPORTATION

TEMPORARY LINEAR SEDIMENT BARRIER  
 (TYPE SANDBAG)

NO SCALE

ALL DIMENSIONS ARE IN MILLIMETERS UNLESS OTHERWISE SHOWN





Standard Symbol

- BMP Objectives**
- Soil Stabilization
  - Sediment Control
  - Tracking Control
  - Wind Erosion Control
  - Non-Storm Water Management
  - Materials and Waste Management

**Definition and Purpose**

A straw bale barrier is a temporary linear sediment barrier consisting of straw bales, designed to intercept and slow sediment-laden sheet flow runoff. Straw bale barriers allow sediment to settle from runoff before water leaves the construction site.

**Appropriate Applications**

- This BMP may be implemented on a project-by-project basis in addition to other BMPs when determined necessary and feasible by the Resident Engineer (RE).
- Along the perimeter of a site.
- Along streams and channels.
- Below the toe of exposed and erodible slopes.
- Down slope of exposed soil areas.
- Around stockpiles.
- Across minor swales or ditches with small catchments.
- Around above grade type temporary concrete washouts (See BMP WM-8, “Concrete Waste Management”).
- Parallel to a roadway to keep sediment off paved areas.

- Limitations
- Installation can be labor intensive.
  - Straw bale barriers are maintenance intensive.
  - Degraded straw bales may fall apart when removed or left in place for extended periods.
  - Can't be used on paved surfaces.
  - Not to be used for drain inlet protection.
  - Shall not be used in areas of concentrated flow.
  - Can be an attractive food source for some animals.
  - May introduce undesirable non-native plants to the area.

## Standards and Specifications

### **Materials**

- **Straw Bale Material:** Straw bale materials shall conform to the provisions in Standard Specifications Section 20-2.06, "Straw."
- **Straw Bale Size:** Each straw bale shall be a minimum of 360 mm (14 in) wide, 450 mm (18 in) in height, 900 mm (36 in) in length and shall have a minimum mass of 23 kg (51 lb.) The straw bale shall be composed entirely of vegetative matter, except for the binding material.
- **Bale Bindings:** Bales shall be bound by either steel wire, nylon or polypropylene string placed horizontally. Jute and cotton binding shall not be used. Baling wire shall be a minimum diameter of 1.57 mm (0.06 inch). Nylon or polypropylene string shall be approximately 2 mm (0.08 inch) in diameter with a breaking strength of 360 N.
- **Stakes:** Wood stakes shall be commercial quality lumber of the size and shape shown on the plans. Each stake shall be free from decay, splits or cracks longer than the thickness of the stake, or other defects that would weaken the stakes and cause the stakes to be structurally unsuitable. Steel bar reinforcement shall be equal to a number four designation or greater. End protection shall be provided for any exposed bar reinforcement.

### **Installation**

- Limit the drainage area upstream of the barrier to 0.3 ha/100 m (0.25 ac/100ft) or barrier.
- Limit the slope length draining to the straw bale barrier to 30 m (100 ft.)

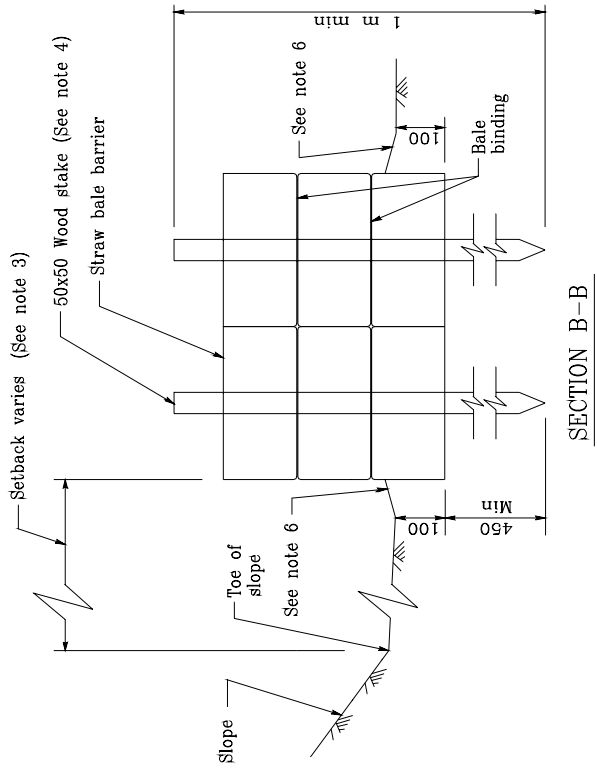
- Slopes of 2:100 (V:H) (2%) or flatter are preferred. If the slope exceeds 1:10 (V:H) (10%), the length of slope upstream of the barrier must be less than 15 m (50 ft).
- Install straw bale barriers along a level contour, with the last straw bale turned up slope.
- Straw bales must be installed in a trench and tightly abut adjacent bales.
- Construct straw bale barriers with a set-back of at least 1 m (3 ft) from the toe of a slope. Where it is determined to be not practical due to specific site conditions, the straw bale barrier may be constructed at the toe of the slope, but shall be constructed as far from the toe of the slope as practical.
- See pages 4 and 5 of this BMP for installation detail.

## Maintenance and Inspection

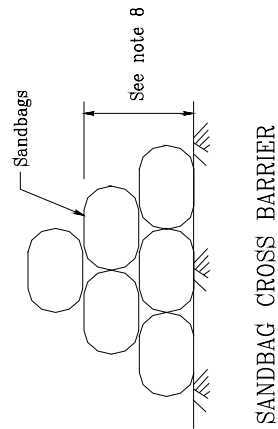
- Inspect straw bale barriers before and after each rainfall event, and weekly throughout the rainy season.
- Inspect straw bale barriers for sediment accumulations and remove sediment when depth reaches one-third the barrier height. Removed sediment shall be incorporated in the project at locations designated by the RE or disposed of outside the highway right-of-way in conformance with the Standard Specifications.
- Replace or repair damage bales as needed or as directed by the RE.
- Repair washouts or other damages as needed or as directed by the RE.
- Remove straw bales when no longer needed. Remove sediment accumulation, and clean, re-grade, and stabilized the area.

# Straw Bale Barrier

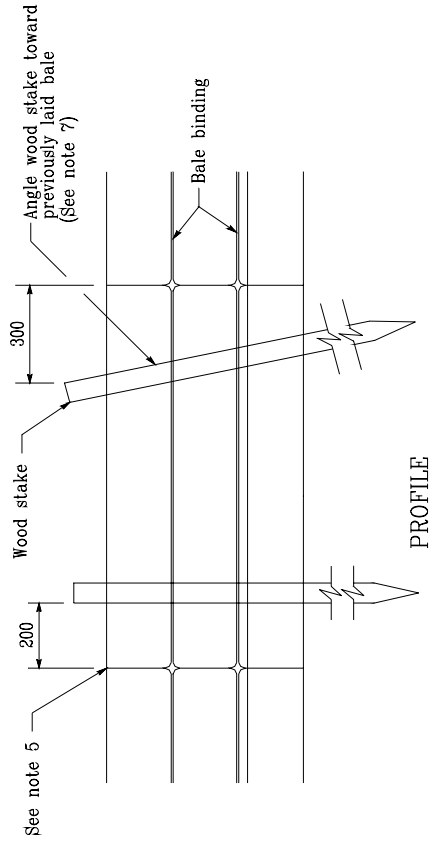
SC-9



SECTION B-B



SANDBAG CROSS BARRIER



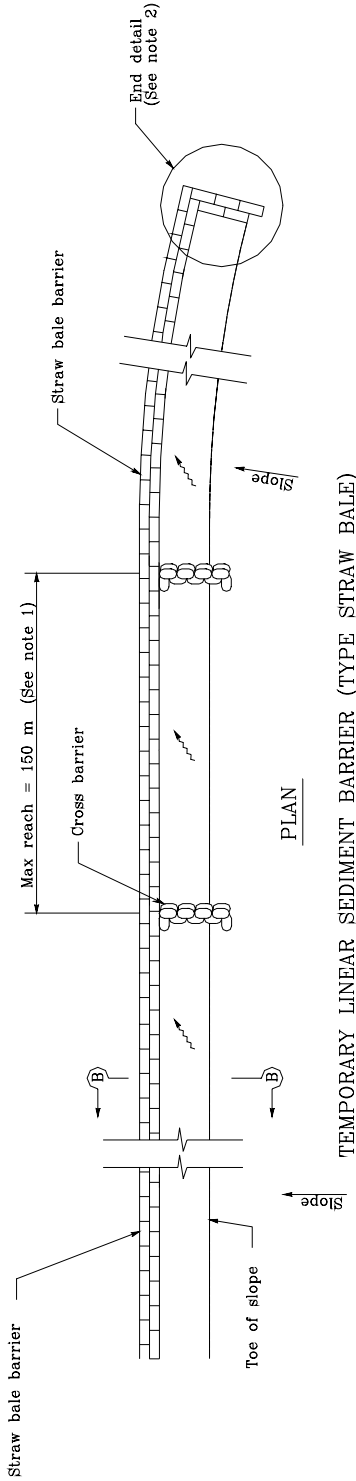
PROFILE

STATE OF CALIFORNIA  
DEPARTMENT OF TRANSPORTATION  
TEMPORARY LINEAR SEDIMENT BARRIER  
(TYPE STRAW BALE)  
NO SCALE  
ALL DIMENSIONS ARE IN  
MILLIMETERS UNLESS OTHERWISE SHOWN

LEGEND

DIRECTION OF FLOW





**NOTES**

1. Construct the length of each reach so that the change in base elevation along the reach does not exceed 1/2 the height of linear barrier. In no case shall the reach length exceed 150 m.

2. End of barrier shall be turned up slope

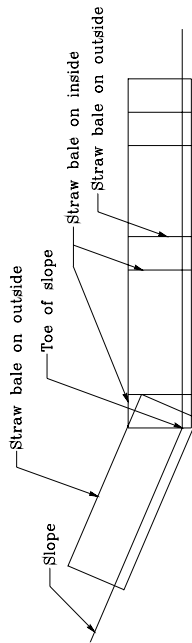
3. Dimension may vary to fit field condition

4. Place

5. Tamp

6. Cross

7. ndba

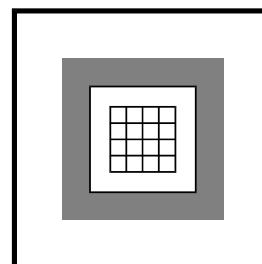
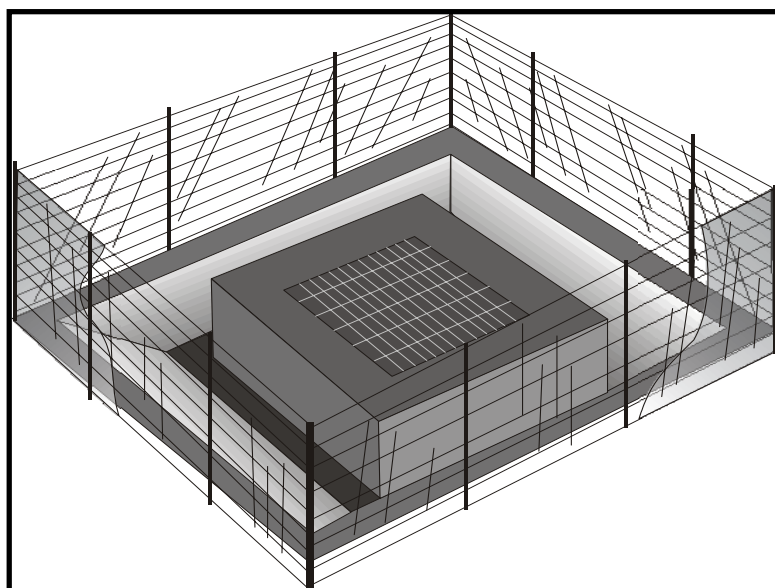


STATE OF CALIFORNIA  
DEPARTMENT OF TRANSPORTATION

TEMPORARY LINEAR SEDIMENT BARRIER  
(TYPE STRAW BALE)

NO SCALE

ALL DIMENSIONS ARE IN  
MILLIMETERS UNLESS OTHERWISE SHOWN



Standard Symbol

### BMP Objectives

- Soil Stabilization
- Sediment Control
- Tracking Control
- Wind Erosion Control
- Non-Storm Water Management
- Materials and Waste Management

### Definition and Purpose

Devices used at storm drain inlets that are subject to runoff from construction activities to detain and/or to filter sediment-laden runoff to allow sediment to settle and/or to filter sediment prior to discharge into storm drainage systems or watercourses.

### Appropriate Applications

- Where ponding will not encroach into highway traffic.
- Where sediment laden surface runoff may enter an inlet.
- Where disturbed drainage areas have not yet been permanently stabilized.
- Where the drainage area is 0.4 ha (1 ac) or less.
- Appropriate during wet and snow-melt seasons.

### Limitations

- Requires an adequate area for water to pond without encroaching upon traveled way and should not present itself to be an obstacle to oncoming traffic.
- May require other methods of temporary protection to prevent sediment-laden storm water and non-storm water discharges from entering the storm drain system.
- Sediment removal may be difficult in high flow conditions or if runoff is heavily sediment laden. If high flow conditions are expected, use other on-site sediment trapping techniques (e.g. check dams) in conjunction with inlet protection.
- Frequent maintenance is required.
- For drainage areas larger than 0.4 ha (1 ac), runoff shall be routed to a sediment trapping device designed for larger flows. See BMPs SC-2, "Sediment/Desilting Basin," and SC-3 "Sediment Trap."

- Filter fabric fence inlet protection is appropriate in open areas that are subject to sheet flow and for flows not exceeding 0.014 m<sup>3</sup>/s (0.5 cfs).
- Gravel bag barriers for inlet protection are applicable when sheet flows or concentrated flows exceed 0.014 m<sup>3</sup>/s (0.5 cfs), and it is necessary to allow for overtopping to prevent flooding.
- Fiber rolls and foam barriers are not appropriate for locations where they cannot be properly anchored to the surface.
- Excavated drop inlet sediment traps are appropriate where relatively heavy flows are expected and overflow capability is needed.

## Standards and Specifications

Identify existing and/or planned storm drain inlets that have the potential to receive sediment-laden surface runoff. Determine if storm drain inlet protection is needed, and which method to use.

### **Methods and Installation**

- **DI Protection Type 1 - Filter Fabric Fence** - The filter fabric fence (Type 1) protection is illustrated on Page 5. Similar to constructing a silt fence. See BMP SC-1, "Silt Fence." Do not place filter fabric underneath the inlet grate since the collected sediment may fall into the drain inlet when the fabric is removed or replaced.
- **DI Protection Type 2 - Excavated Drop Inlet Sediment Trap** - The excavated drop inlet sediment trap (Type 2) is illustrated in Page 6. Similar to constructing a temporary silt fence, See BMP SC-1, "Silt Fence." Size excavated trap to provide a minimum storage capacity calculated at the rate of 130 m<sup>3</sup>/ha (67 yd<sup>3</sup>/ac) of drainage area.
- **DI Protection Type 3 - Gravel bag** - The gravel bag barrier (Type 3) is illustrated in Page 7. Flow from a severe storm shall not overtop the curb. In areas of high clay and silts, use filter fabric and gravel as additional filter media. Construct gravel bags in accordance with BMP SC-6, "Gravel Bag Berm." Gravel bags shall be used due to their high permeability.
- **DI Protection Type 4 - Foam Barriers and Fiber Rolls** - Foam barrier or fiber roll (Type 4) is placed around the inlet and keyed and anchored to the surface. Foam barriers and fiber rolls are intended for use as inlet protection where the area around the inlet is unpaved and the foam barrier or fiber roll can be secured to the surface. RE or Construction Storm Water Coordinator approval is required.

## Maintenance and Inspection

### **General**

- Inspect all inlet protection devices before and after every rainfall event, and weekly during the rest of the rainy season. During extended rainfall events, inspect inlet protection devices at least once every 24 hours.

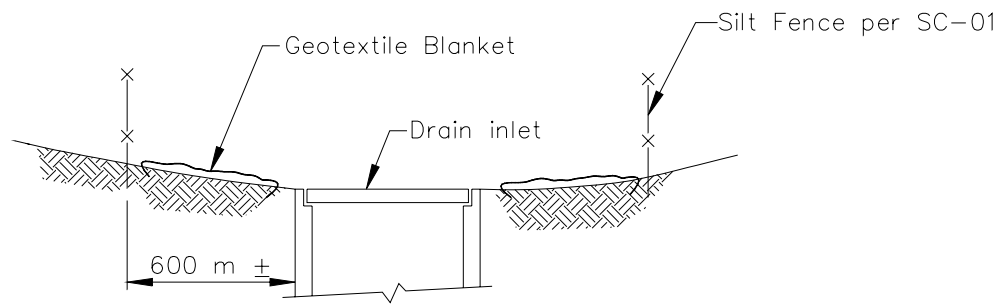
- Inspect the storm drain inlet after severe storms in the rainy season to check for bypassed material.
- Remove all inlet protection devices within thirty days after the site is stabilized, or when the inlet protection is no longer needed.
  - Bring the disturbed area to final grade and smooth and compact it. Appropriately stabilize all bare areas around the inlet.
  - Clean and re-grade area around the inlet and clean the inside of the storm drain inlet as it must be free of sediment and debris at the time of final inspection.

### **Requirements by Method**

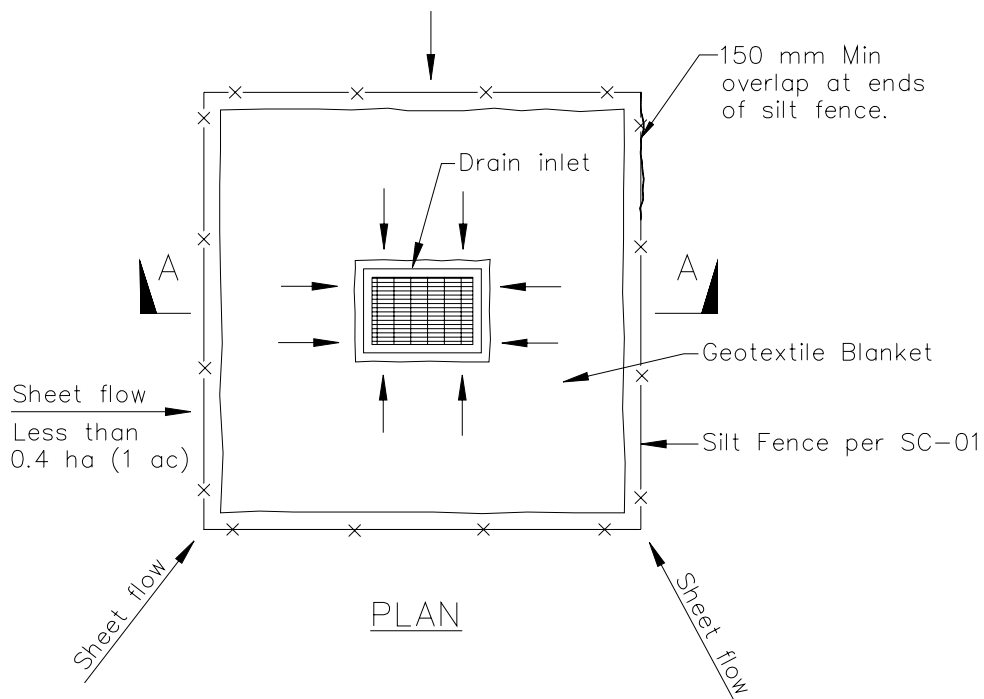
- **Type 1 - Filter Fabric Fence**
  - This method shall be used for drain inlets requiring protection in areas where finished grade is established and erosion control seeding has been applied or is pending.
  - Make sure the stakes are securely driven in the ground and are structurally sound (i.e., not bent, cracked, or splintered, and are reasonably perpendicular to the ground). Replace damaged stakes.
  - Replace or clean the fabric when the fabric becomes clogged with sediment. Make sure the fabric does not have any holes or tears. Repair or replace fabric as needed or as directed by the RE.
  - At a minimum, remove the sediment behind the fabric fence when accumulation reaches one-third the height of the fence or barrier height. Removed sediment shall be incorporated in the project at locations designated by the RE or disposed of outside the highway right-of-way in conformance with the Standard Specifications Section 7-1.13.
- **Type 2 - Excavated Drop Inlet Sediment Trap**
  - This method may be used for drain inlets requiring protection in areas that have been cleared and grubbed, and where exposed soil areas are subject to grading.
  - Remove sediment from basin when the volume of the basin has been reduced by one-half.
- **Type 3 - Gravel Bag Barrier**
  - This method may be used for drain inlets surrounded by AC or paved surfaces.
  - Inspect bags for holes, gashes, and snags.



- Check gravel bags for proper arrangement and displacement. Remove the sediment behind the barrier when it reaches one-third the height of the barrier. Removed sediment shall be incorporated in the project at locations designated by the RE or disposed of outside the highway right-of-way in conformance with the Standard Specifications Section 7-1.13.
  
- ***Type 4 Foam Barriers and Fiber Rolls***
  - This method may be used for drain inlets requiring protection in areas that have been cleared and grubbed, and where exposed soil areas subject to grading. RE or Construction Storm Coordinator approval is required.
  
  - Check foam barrier or fiber roll for proper arrangement and displacement. Remove the sediment behind the barrier when it reaches one-third the height of the barrier. Removed sediment shall be incorporated in the project at locations designated by the RE or disposed of outside the highway right-of-way in conformance with the Standard Specifications.



SECTION A-A

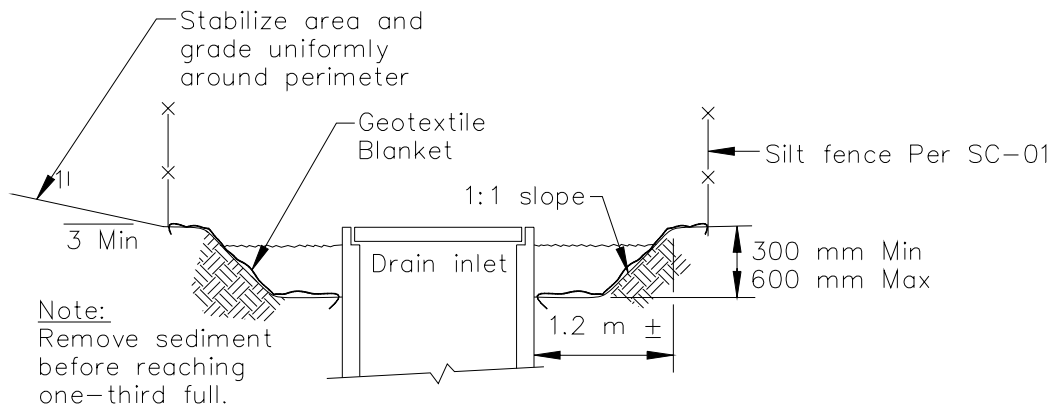


PLAN

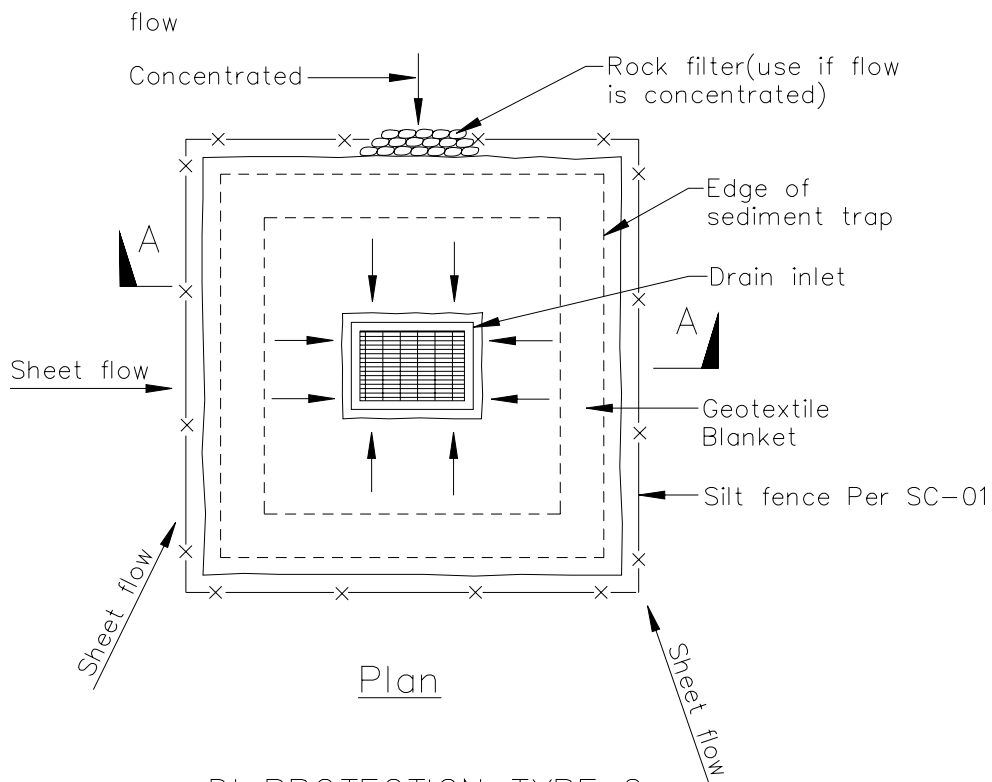
DI PROTECTION TYPE 1  
NOT TO SCALE

NOTES:

1. For use in areas where grading has been completed and final soil stabilization and seeding are pending.
2. Not applicable in paved areas.
3. Not applicable with concentrated flows.



Section A-A

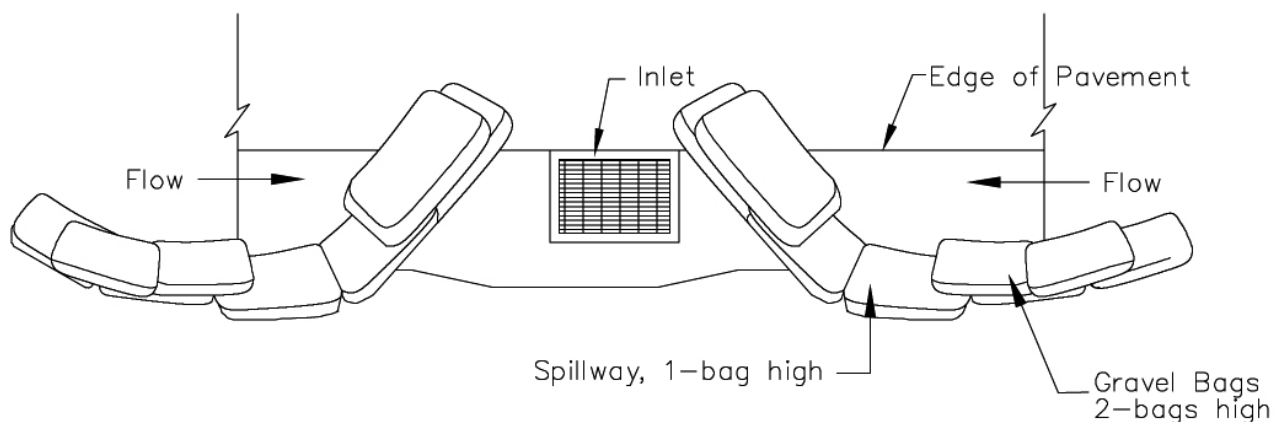


Plan

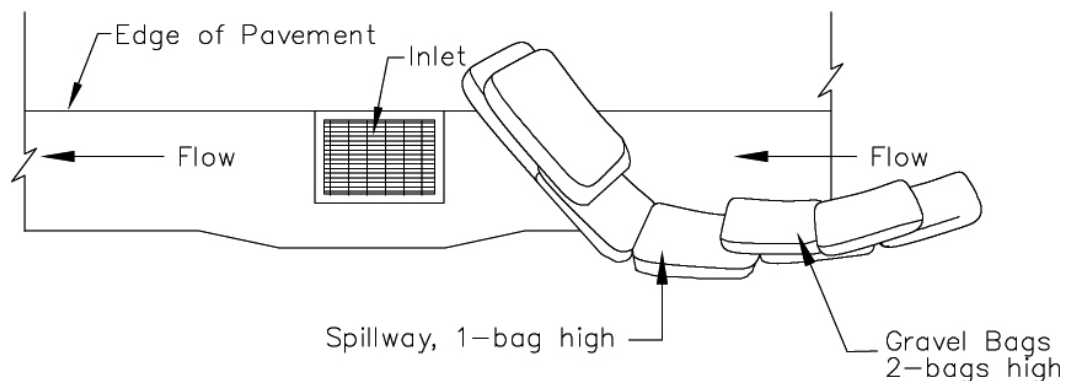
DI PROTECTION TYPE 2  
NOT TO SCALE

Notes

1. For use in cleared and grubbed and in graded areas.
2. Shape basin so that longest inflow area faces longest length of trap.
3. For concentrated flows, shape basin in 2:1 ratio with length oriented towards direction of flow.



**TYPICAL PROTECTION FOR INLET WITH OPPOSING FLOW DIRECTIONS**



**TYPICAL PROTECTION FOR INLET WITH SINGLE FLOW DIRECTION**

NOTES:

1. Intended for short-term use.
2. Use to inhibit non-storm water flow.
3. Allow for proper maintenance and cleanup.
4. Bags must be removed after adjacent operation is completed
5. Not applicable in areas with high silts and clays without filter fabric.