

Standard Symbol

- BMP Objectives**

 - Soil Stabilization
 - Sediment Control
 - Tracking Control
 - Wind Erosion Control
 - Non-Storm Water Management
 - Materials and Waste Management

Definition and Purpose Hydraulic mulch consists of applying a mixture of shredded wood fiber or a hydraulic matrix and a stabilizing emulsion or tackifier with hydroseeding equipment, which temporarily protects exposed soil from erosion by raindrop impact or wind. This is one of five temporary soil stabilization alternatives to consider.

Appropriate Applications ■ Hydraulic mulch is applied to disturbed areas requiring temporary protection until permanent vegetation is established or disturbed areas that must re-disturbed following an extended period of inactivity.

- Limitations**
- Wood fiber hydraulic mulches are generally short-lived (only last a part of a growing season) and need 24 hours to dry before rainfall occurs to be effective.
 - Paper mulches are not permitted.
 - Avoid use in areas where the mulch would be incompatible with immediate future earthwork activities and would have to be removed.

- Standards and Specifications**
- Prior to application, roughen embankment and fill areas by rolling with a crimping or punching type roller or by track walking. Track walking shall only be used where other methods are impractical.
 - Hydraulic matrices require 24 hours to dry before rainfall occurs to be effective unless approved by the Resident Engineer.
 - Avoid mulch over-spray onto the traveled way, sidewalks, lined drainage channels, and existing vegetation.
 - Selection of hydraulic mulches by the Contractor must be approved by the Resident Engineer (RE) or Construction Storm Water Coordinator.

- Materials for wood fiber based hydraulic mulches and hydraulic matrices shall conform to Standard Specifications Section 20-2.07.
- Hydraulic Mulch
- Wood fiber mulch is a component of hydraulic applications. It is typically applied at the rate of 2,250 to 4,500 kilograms per hectare (kg/ha) (2,000 to 4,000 lb/ac) with 0-5% by weight of a stabilizing emulsion or tackifier (e.g., guar, psyllium, acrylic copolymer) and applied as a slurry. This type of mulch is manufactured from wood or wood waste from lumber mills or from urban sources. Specifications for wood fiber mulch can be found in Standard Specifications Sections 20-2.07 and 20-2.08.
- Hydraulic matrix is a combination of wood fiber mulch and a tackifier applied as a slurry. It is typically applied at the rate of 2,250 to 4,500 kilograms per hectare (kg/Ha) with 5-10% by weight of a stabilizing emulsion or tackifier (e.g., guar, psyllium, acrylic copolymer).
- Hydraulic Matrix
- Hydraulic matrix is a combination of wood fiber mulch and tackifier applied as a slurry. It is typically applied at the rate of 2,250 to 4,500 kg/ha with 5-10% by weight of a stabilizing emulsion or tackifier (e.g., guar, psyllium, acrylic copolymer).
- Bonded Fiber Matrix
- Bonded fiber matrix (BFM) is a hydraulically-applied system of fibers and adhesives that upon drying forms an erosion-resistant blanket that promotes vegetation, and prevents soil erosion. BFMs are typically applied at rates from 3,400 kg/ha to 4,500 kg/ha based on the manufacturer's recommendation. The biodegradable BFM is composed of materials that are 100% biodegradable. The binder in the BFM should also be biodegradable and should not dissolve or disperse upon re-wetting. Typically, biodegradable BFMs should not be applied immediately before, during or immediately after rainfall if the soil is saturated. Depending on the product, BFMs require 12 to 24 hours to dry to become effective.

Maintenance and Inspections

- Maintain an unbroken, temporary mulched ground cover throughout the period of construction when the soils are not being reworked. Inspect before expected rain storms and repair any damaged ground cover and re-mulch exposed areas of bare soil.
- After any rainfall event, the Contractor is responsible for maintaining all slopes to prevent erosion.

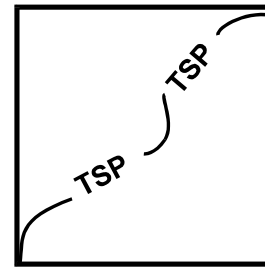
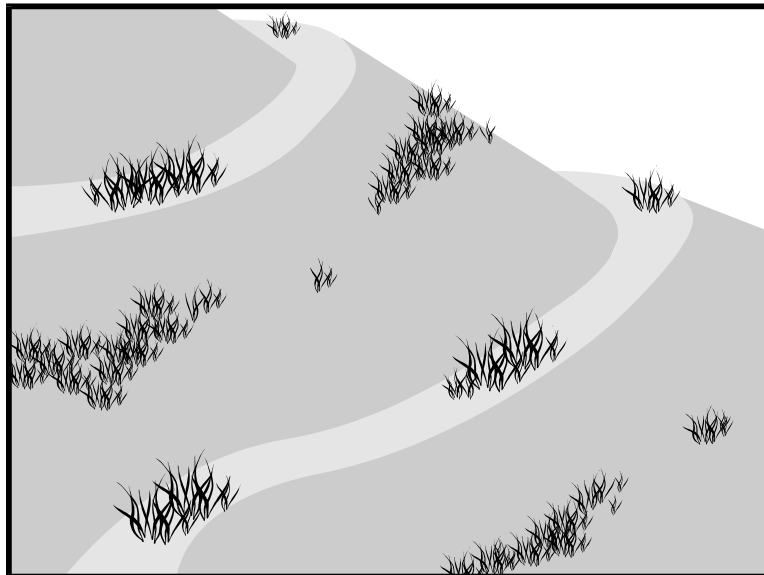

Standard Symbol

BMP Objectives

- Soil Stabilization
- Sediment Control
- Tracking Control
- Wind Erosion Control
- Non-Storm Water Management
- Materials and Waste Management

Definition and Purpose Hydroseeding typically consists of applying a mixture of wood fiber, seed, fertilizer, and stabilizing emulsion with hydro-mulch equipment, which temporarily protects exposed soils from erosion by water and wind. This is one of five temporary soil stabilization alternatives to consider.

Appropriate Applications

- Hydroseeding is applied on disturbed soil areas requiring temporary protection until permanent vegetation is established or disturbed soil areas that must be re-disturbed following an extended period of inactivity.

Limitations

- Hydroseeding may be used alone only when there is sufficient time in the season to ensure adequate vegetation establishment and erosion control. Otherwise, hydroseeding must be used in conjunction with a soil binder or mulching (i.e., straw mulch), refer to BMP SS-5, Table 1 for options.
- Steep slopes are difficult to protect with temporary seeding.
- Temporary seeding may not be appropriate in dry periods without supplemental irrigation.
- Temporary vegetation may have to be removed before permanent vegetation is applied.
- Temporary vegetation is not appropriate for short-term inactivity.

Standards and Specifications To select appropriate hydroseeding mixtures, an evaluation of site conditions shall be performed with respect to:

- Soil conditions
- Site topography
- Season and climate
- Vegetation types
- Maintenance requirements
- Sensitive adjacent areas
- Water availability
- Plans for permanent vegetation

- Selection of hydroseeding mixtures shall be approved by the District Landscape Architect and the Construction Storm Water Coordinator.

The following steps shall be followed for implementation:

- Seed mix shall comply with the Standard Specifications Section 20-2.10, and the project's special provisions.
- Hydroseeding can be accomplished using a multiple-step or one-step process; refer to the special provisions for specified process. The multiple-step process ensures maximum direct contact of the seeds to soil. When the one-step process is used to apply the mixture of fiber, seed, etc., the seed rate shall be increased to compensate for all seeds not having direct contact with the soil.
- Prior to application, roughen the slope, fill area, or area to be seeded with the furrows trending along the contours. Rolling with a crimping or punching type roller or track walking is required on all slopes prior to hydroseeding. Track walking shall only be used where other methods are impractical.
- Apply a straw mulch to keep seeds in place and to moderate soil moisture and temperature until the seeds germinate and grow, refer to Standard Specifications Sections 20-2.06 and 20-3.03.
- All seeds shall be in conformance with the California State Seed Law of the Department of Agriculture. Each seed bag shall be delivered to the site sealed and clearly marked as to species, purity, percent germination, dealer's guarantee, and dates of test; provide the Resident Engineer (RE) with such documentation. The container shall be labeled to clearly reflect the amount of Pure Live Seed (PLS) contained. All legume seed shall be pellet-inoculated. Inoculant sources shall be species-specific and shall be applied at a rate of 2 kg of inoculant per 100 kg of seed (2-lb inoculant per 100-lb seed), refer to Standard Specifications Section 20-2.10.
- Commercial fertilizer shall conform to the requirements of the California Food and Agricultural Code. Fertilizer shall be pelleted or granular form.

Maintenance and Inspection

- Follow-up applications shall be made as needed to cover weak spots, and to maintain adequate soil protection.
- Avoid over-spray onto the traveled way, sidewalks, lined drainage channels, and existing vegetation.
- All seeded areas shall be inspected for failures and re-seeded, fertilized, and mulched within the planting season, using not less than half the original application rates. Any temporary revegetation efforts that do not provide adequate cover must be reapplied at a scheduled recommended by the Caltrans Landscape Architect or RE.
- After any rainfall event, the Contractor is responsible for maintaining all slopes to prevent erosion.

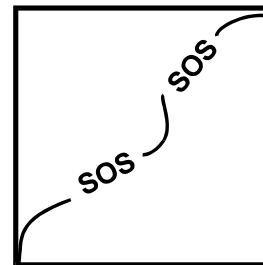
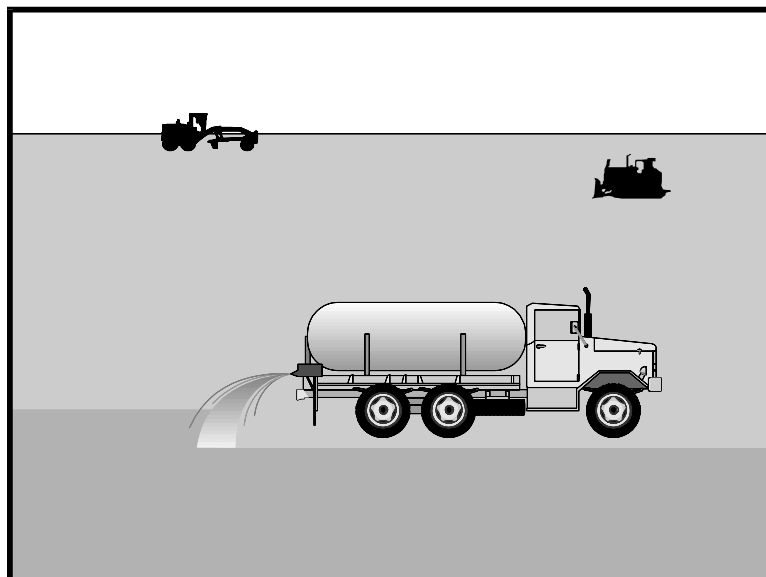

Standard Symbol

- BMP Objectives**

 - Soil Stabilization
 - Sediment Control
 - Tracking Control
 - Wind Erosion Control
 - Non-Storm Water Management
 - Materials and Waste Management

Definition and Purpose Soil binders consist of applying and maintaining a soil stabilizer to exposed soil surfaces. Soil binders are materials applied to the soil surface to temporarily prevent water-induced erosion of exposed soils on construction sites. Soil binders also provide temporary dust, wind, and soil stabilization (erosion control) benefits. This is one of five temporary soil stabilization alternatives to consider.

Appropriate Applications Soil binders are typically applied to disturbed areas requiring short-term temporary protection. Because soil binders can often be incorporated into the work, they may be a good choice for areas where grading activities will soon resume. Application on stockpiles to prevent water and wind erosion.

- Limitations**
- Soil binders are temporary in nature and may need reapplication.
 - Soil binders require a minimum curing time until fully effective, as prescribed by the manufacturer, which may be 24 hours or longer. Soil binders may need reapplication after a storm event.
 - Soil binders will generally experience spot failures during heavy rainfall events. If runoff penetrates the soil at the top of a slope treated with a soil binder, it is likely that the runoff will undercut the stabilized soil layer and discharge at a point further down slope.
 - Soil binders do not hold up to pedestrian or vehicular traffic across treated areas.
 - Soil binders may not penetrate soil surfaces made up primarily of silt and clay, particularly when compacted.
 - Storm water quality runoff sampling is required for many soil binders. Soil binders that do not require sampling are identified in the Caltrans SWPPP/WPCP Preparation Manual, Pollutant Table, Attachment S.

- Some soil binders may not perform well with low relative humidity. Under rainy conditions, some agents may become slippery or leach out of the soil.
- May not cure if low temperatures occur within 24 hours of application.

Standards and Specifications

General Considerations

- Site-specific soil types will dictate appropriate soil binders to be used.
- A soil binder must be environmentally benign (non-toxic to plant and animal life), easy to apply, easy to maintain, economical, and shall not stain paved or painted surfaces, refer to Standard Specifications Section 20-2.11.
- Some soil binders are compatible with existing vegetation.
- Performance of soil binders depends on temperature, humidity, and traffic across treated areas.
- Avoid over-spray onto the traveled way, sidewalks, lined drainage channels, and existing vegetation.

Soil Binders Applications

After selecting an appropriate soil binder, the untreated soil surface must be prepared before applying the soil binder. The untreated soil surface must contain sufficient moisture to assist the agent in achieving uniform distribution. In general, the following steps shall be followed:

- Follow manufacturer's recommendations for application rates, pre-wetting of application area, and cleaning of equipment after use.
- Prior to application, roughen embankment and fill areas by rolling with a crimping or punching type roller or by track walking. Track walking shall only be used where rolling is impractical.
- Consider the drying time for the selected soil binder and apply with sufficient time before anticipated rainfall. Soil binders shall not be applied during or immediately before rainfall.
- Avoid over-spray onto the traveled way, sidewalks, lined drainage channels, sound walls, and existing vegetation.
- Soil binders shall not be applied to frozen soil, areas with standing water, under freezing or rainy conditions, or when the air temperature is below 40C (40oF) during the curing period.
- More than one treatment is often necessary, although the second treatment may be diluted or have a lower application rate.
- Generally, soil binders require a minimum curing time of 24 hours before they are fully effective. Refer to manufacturer's instructions for specific cure times.

- For liquid agents:
 - Crown or slope ground to avoid ponding.
 - Uniformly pre-wet ground at 0.14 to 1.4 L/m² (0.03 to 0.3 gal/yd²) or according to manufacturer's recommendations.
 - Apply solution under pressure. Overlap solution 150 to 300 mm (6 to 12 in).
 - Allow treated area to cure for the time recommended by the manufacturer; typically, at least 24 hours.
 - In low humidities, reactivate chemicals by re-wetting with water at 0.5 to 0.9 L/m² (0.1 to 0.2 gal/yd²).

Selecting a Soil Binder

Properties of common soil binders used for erosion control are provided in Table 1 and Appendix B. Use Table 1 to select an appropriate soil binder.

Factors to consider when selecting a soil binder include the following:

- Suitability to situation - Consider where the soil binder will be applied; determine if it needs a high resistance to leaching or abrasion, and whether it needs to be compatible with any existing vegetation. Determine the length of time soil stabilization will be needed, and if the soil binder will be placed in an area where it will degrade rapidly. In general, slope steepness is not a discriminating factor for the listed soil binders.
- Soil types and surface materials - Fines and moisture content are key properties of surface materials. Consider a soil binder's ability to penetrate, likelihood of leaching, and ability to form a surface crust on the surface materials.
- Frequency of application - The frequency of application can be affected by subgrade conditions, surface type, climate, and maintenance schedule. Frequent applications could lead to high costs. Application frequency may be minimized if the soil binder has good penetration, low evaporation, and good longevity. Consider also that frequent application will require frequent equipment clean-up.

After considering the above factors, the soil binders in Table 1 will be generally appropriate as follows:

Plant-Material Based (Short Lived)

-Guar: Guar is a non-toxic, biodegradable, natural galactomannan-based hydrocolloid treated with dispersent agents for easy field mixing. It shall be diluted at the rate of 1.2 to 1.8 kg per 1,000 liters (1 to 5 lb per 100 gallons) of water, depending on application machine capacity. Recommended minimum application rates are as follows:

Application Rates for Guar Soil Stabilizer

Slope (V:H):	Flat	1:4	1:3	1:2	1:1
Kg/Ha:	45	50	56	67	78
lb/ac	40	45	50	60	70

-Psyllium: Psyllium is composed of the finely ground muciloid coating of plantago seeds that is applied as a dry powder or in a wet slurry to the surface of the soil. It dries to form a firm but rewettable membrane that binds soil particles together but permits germination and growth of seed. Psyllium requires 12 to 18 hours drying time. Psyllium shall be applied at a rate of 90 to 225 kg/ha (80 to 200 lb/ac), with enough water in solution to allow for a uniform slurry flow.

-Starch: Starch is non-ionic, cold-water soluble (pre-gelatinized) granular cornstarch. The material is mixed with water and applied at the rate of 170 kg/ha (150 lb/ac). Approximate drying time is 9 to 12 hours.

Plant-Material Based (Long Lived)

-Pitch and Rosin Emulsion: Generally, a non-ionic pitch and rosin emulsion has a minimum solids content of 48%. The rosin shall be a minimum of 26% of the total solids content. The soil stabilizer shall be non-corrosive, water-dilutable emulsion that upon application cures to a water insoluble binding and cementing agent. For soil erosion control applications, the emulsion is diluted and shall be applied as follows:

For clayey soil: 5 parts water to 1 part emulsion

For sandy soil: 10 parts water to 1 part emulsion

Application can be by water truck or hydraulic seeder with the emulsion/product mixture applied at the rate specified by the manufacturer. Approximate drying time is 19 to 24 hours.

Polymeric Emulsion Blends

-Acrylic Copolymers and Polymers: Polymeric soil stabilizers shall consist of a liquid or solid polymer or copolymer with an acrylic base that contains a minimum of 55% solids. The polymeric compound shall be handled and mixed in a manner that will not cause foaming or shall contain an anti-foaming agent. The polymeric emulsion shall not exceed its shelf life or expiration date; manufacturers shall provide the expiration date. Polymeric soil stabilizer shall be readily miscible in water, non-injurious to seed or animal life, non-flammable, shall provide surface soil stabilization for various soil types without totally inhibiting water infiltration, and shall not re-emulsify when cured. The applied compound shall air cure within a maximum of 36 to 48 hours. Liquid copolymer shall be diluted at a rate of 10 parts water to 1 part polymer and applied to soil at a rate of 11,000 liters/hectare (1,175 gal/ac).

-Liquid Polymers of Methacrylates and Acrylates: This material consists of a tackifier/sealer that is a liquid polymer of methacrylates and acrylates. It is an aqueous 100% acrylic emulsion blend of 40% solids by volume that is free from styrene, acetate, vinyl, ethoxylated surfactants or silicates. For soil stabilization applications, it is diluted with water in accordance with manufacturer's recommendations, and applied with a hydraulic seeder at the rate of 190 L/ha (20 gal/ac). Drying time is 12 to 18 hours after application.

-Copolymers of Sodium Acrylates and Acrylamides: These materials are non-toxic, dry powders that are copolymers of sodium acrylate and acrylamide. They are mixed with water and applied to the soil surface for erosion control at rates that are determined by slope gradient:

Slope Gradient (V:H)	kg/ha (lb/ac)
Flat to 1:5	3.4 – 5.6 (3-5)
1:5 to 1:3	5.6 – 11.2 (5-10)
1:2 to 1:1	11.2 – 22.4 (10-20)

-Poly-Acrylamide and Copolymer of Acrylamide: Linear copolymer polyacrylamide is packaged as a dry-flowable solid. When used as a stand-alone stabilizer, it is diluted at a rate of 1.5 kg/1,000 liters (1 lb/100 gal) of water and applied at the rate of 5.6 kg/ha (5 lb/ac).

-Hydro-Colloid Polymers: Hydro-Colloid Polymers are various combinations of dry-flowable poly-acrylamides, copolymers and hydro-colloid polymers that are mixed with water and applied to the soil surface at rates of 60 to 70 kg/ha (53 to 62 lb/ac). Drying times are 0 to 4 hours.

Cementitious-Based Binders

-Gypsum: This is a formulated gypsum-based product that readily mixes with water and mulch to form a thin protective crust on the soil surface. It is composed of high purity gypsum that is ground, calcined and processed into calcium sulfate hemihydrate with a minimum purity of 86%. It is mixed in a hydraulic seeder and applied at rates 4,500 to 13,500 kg/ha (4,000 to 12,000 lb/ac). Drying time is 4 to 8 hours.

- Maintenance and Inspection**
- Reapplying the selected soil binder may be needed for proper maintenance. High traffic areas shall be inspected daily, and lower traffic areas shall be inspected weekly.
 - After any rainfall event, the Contractor is responsible for maintaining all slopes to prevent erosion.
 - Maintain an unbroken, temporary stabilized area while DSAs are nonactive. Repair any damaged stabilized area and re-apply soil binder to exposed areas.

Table 1 Properties of Soil Binders for Erosion Control				
Chemicals	Plant Material Based (Short Lived)	Plant Material Based (Long Lived)	Polymeric Emulsion Blends	Cementitious-Based Binders
Relative Cost	Low	Low	Low	Low
Resistance to Leaching	High	High	Low to Moderate	Moderate
Resistance to Abrasion	Moderate	Low	Moderate to High	Moderate to High
Longevity	Short to Medium	Medium	Medium to Long	Medium
Minimum Curing Time before Rain	9 to 18 hours	19 to 24 hours	0 to 24 hours	4 to 8 hours
Compatibility with Existing Vegetation	Good	Poor	Poor	Poor
Mode of Degradation	Biodegradable	Biodegradable	Photodegradable/ Chemically Degradable	Photodegradable/ Chemically Degradable
Labor Intensive	No	No	No	No
Specialized Application Equipment	Water Truck or Hydraulic Mulcher	Water Truck or Hydraulic Mulcher	Water Truck or Hydraulic Mulcher	Water Truck or Hydraulic Mulcher
Liquid/Powder	Powder	Liquid	Liquid/Powder	Powder
Surface Crusting	Yes, but dissolves on rewetting	Yes	Yes, but dissolves on rewetting	Yes
Clean-Up	Water	Water	Water	Water
Erosion Control Application Rate	Varies ⁽¹⁾	Varies ⁽¹⁾	Varies ⁽¹⁾	4,500 to 13,500 kg/ha

(1) Dependant on product, soil type, and slope inclination

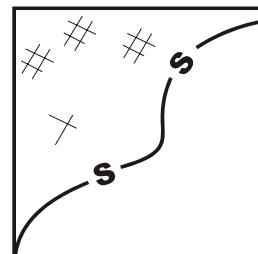
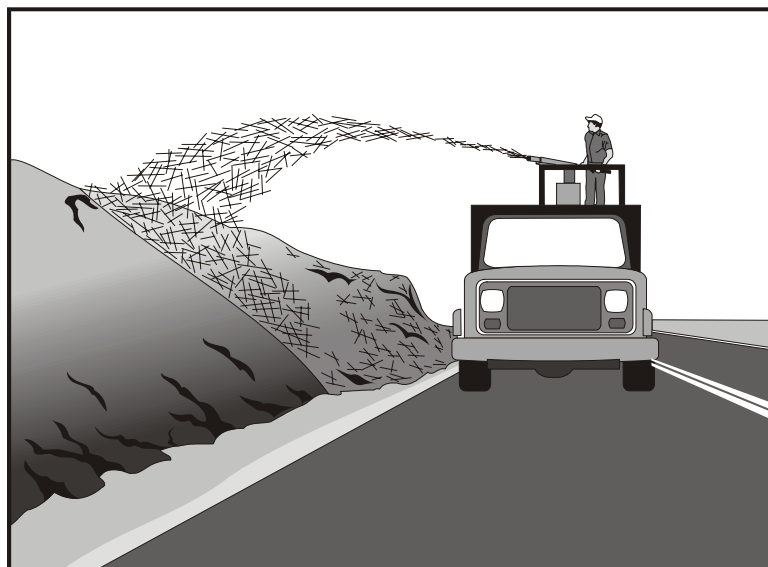

Standard Symbol

BMP Objectives	
●	Soil Stabilization
○	Sediment Control
○	Tracking Control
●	Wind Erosion Control
○	Non-Storm Water Management
○	Materials and Waste Management

Definition and Purpose

Straw mulch consists of placing a uniform layer of straw and incorporating it into the soil with a studded roller or anchoring it with a stabilizing emulsion. This is one of five temporary soil stabilization alternatives to consider.

Appropriate Applications

- Straw mulch is typically used for soil stabilization as a temporary surface cover on disturbed areas until soils can be prepared for revegetation and permanent vegetation is established.
- Also typically used in combination with temporary and/or permanent seeding strategies to enhance plant establishment.

Limitations

- Availability of erosion control contractors and straw may be limited prior to the rainy season due to high demand.
- There is a potential for introduction of weed-seed and unwanted plant material.
- When straw blowers are used to apply straw mulch, the treatment areas must be within 45 m (150 ft) of a road or surface capable of supporting trucks.
- Straw mulch applied by hand is more time intensive and potentially costly.
- May have to be removed prior to permanent seeding or soil stabilization.
- “Punching” of straw does not work in sandy soils.

Standards and Specifications

- Straw shall be derived from wheat, rice, or barley.
- All materials shall conform to Standard Specifications Sections 20-2.06, 20-2.07 and 20-2.11.
- A tackifier is the preferred method for anchoring straw mulch to the soil on slopes.
- Crimping, punch roller-type rollers, or track-walking may also be used to incorporate straw mulch into the soil on slopes. Track walking shall only be used where other methods are impractical.
- Avoid placing straw onto the traveled way, sidewalks, lined drainage channels, sound walls, and existing vegetation.
- Straw mulch with tackifier shall not be applied during or immediately before rainfall.

Application Procedures

- Apply loose straw at a minimum rate of 3,570 kg/ha (4,000 lb/ac), or as indicated in the project's special provisions, either by machine or by hand distribution.
- If stabilizing emulsion will be used to anchor the straw mulch in lieu of incorporation, roughen embankment or fill areas by rolling with a crimping or punching-type roller or by track walking before placing the straw mulch. Track walking should only be used where rolling is impractical.
- The straw mulch must be evenly distributed on the soil surface.
- Anchor the mulch in place by using a tackifier or by "punching" it into the soil mechanically (incorporating).
- A tackifier acts to glue the straw fibers together and to the soil surface. The tackifier shall be selected based on longevity and ability to hold the fibers in place.
- A tackifier is typically applied at a rate of 140 kg/ha (125 lb/ac). In windy conditions, the rates are typically 200 kg/ha (178 lb/ac).
- Methods for holding the straw mulch in place depend upon the slope steepness, accessibility, soil conditions and longevity. If the selected method is incorporation of straw mulch into the soil, then do as follows:
 - Applying and incorporating straw shall follow the requirements in Standard Specifications Section 20-3.03.
 - On small areas, a spade or shovel can be used.

- On slopes with soils, which are stable enough and of sufficient gradient to safely support construction equipment without contributing to compaction and instability problems, straw can be “punched” into the ground using a knife-blade roller or a straight bladed coultter, known commercially as a “crimper.”
- On small areas and/or steep slopes, straw can also be held in place using plastic netting or jute. The netting shall be held in place using 11 gauge wire staples, geotextile pins or wooden stakes. Refer to BMP SS-7, “Geotextiles, Plastic Covers and Erosion Control Blankets/Mats.”

Maintenance and Inspections

- The key consideration in Maintenance and Inspection is that the straw needs to last long enough to achieve erosion control objectives.
- Maintain an unbroken, temporary mulched ground cover while DSAs are non-active. Repair any damaged ground cover and re-mulch exposed areas.
- Reapplication of straw mulch and tackifier may be required by the Resident Engineer (RE) to maintain effective soil stabilization over disturbed areas and slopes.
- After any rainfall event, the Contractor is responsible for maintaining all slopes to prevent erosion.

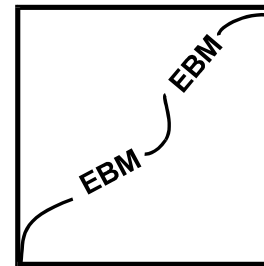
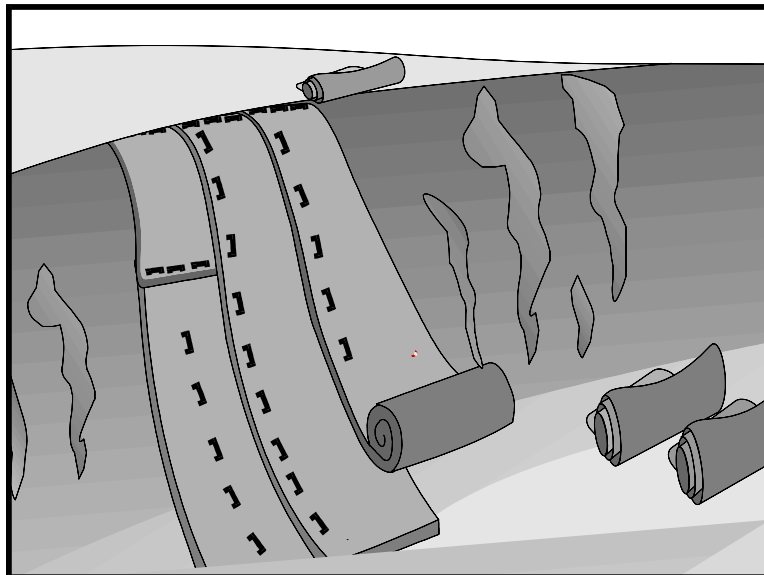

Standard Symbol

BMP Objectives

- Soil Stabilization
- Sediment Control
- Tracking Control
- Wind Erosion Control
- Non-Storm Water Management
- Materials and Waste Management

Definition and Purpose This Best Management Practice (BMP) involves the placement of geotextiles, mats, plastic covers, or erosion control blankets to stabilize disturbed soil areas and protect soils from erosion by wind or water. This is one of five temporary soil stabilization alternatives to consider.

Appropriate Applications These measures are used when disturbed soils may be particularly difficult to stabilize, including the following situations:

- Steep slopes, generally steeper than 1:3 (V:H).
- Slopes where the erosion potential is high.
- Slopes and disturbed soils where mulch must be anchored.
- Disturbed areas where plants are slow to develop.
- Channels with flows exceeding 1.0 m/s (3.3 ft/s).
- Channels to be vegetated.
- Stockpiles.
- Slopes adjacent to water bodies of Environmentally Sensitive Areas (ESAs).

- Limitations
- Blankets and mats are more expensive than other erosion control measures, due to labor and material costs. This usually limits their application to areas inaccessible to hydraulic equipment, or where other measures are not applicable, such as channels.
 - Blankets and mats are generally not suitable for excessively rocky sites, or areas where the final vegetation will be mowed (since staples and netting can catch in mowers).
 - Blankets and mats must be removed and disposed of prior to application of permanent soil stabilization measures.
 - Plastic sheeting is easily vandalized, easily torn, photodegradable, and must be disposed of at a landfill.
 - Plastic results in 100% runoff, which may cause serious erosion problems in the areas receiving the increased flow.
 - The use of plastic shall be limited to covering stockpiles, or very small graded areas for short periods of time (such as through one imminent storm event), until alternative measures, such as seeding and mulching, may be installed.
 - Geotextiles, mats, plastic covers, and erosion control covers have maximum flow rate limitations; consult the manufacturer for proper selection.

Standards and Specifications **Material Selection**

There are many types of erosion control blankets and mats, and selection of the appropriate type shall be based on the specific type of application and site conditions. Selection(s) made by the Contractor must be approved by the Resident Engineer (RE); certification of compliance shall be in accordance with Standard Specifications Section 6-1.07.

Geotextiles

- Material shall be a woven polypropylene fabric with minimum thickness of 1.5 mm (0.06 inch), minimum width of 3.7 m (12 ft) and shall have minimum tensile strength of 0.67 kN (warp) 0.36 kN (fill) in conformance with the requirements in ASTM Designation: D 4632. The permittivity of the fabric shall be approximately 0.07 sec⁻¹ in conformance with the requirements in ASTM Designation: D4491. The fabric shall have an ultraviolet (UV) stability of 70 percent in conformance with the requirements in ASTM designation: D4355. Geotextile blankets shall be secured in place with wire staples or sandbags and by keying into tops of slopes and edges to prevent infiltration of surface waters under Geotextile. Staples shall be made of 3.05-mm (0.12-inch) steel wire and shall be U-shaped with 200-mm (8-inch) legs and 50-mm (2-inch) crown.
- Geotextiles may be reused if, in the opinion of the RE, they are suitable for the use intended.

Plastic Covers

- Plastic sheeting shall have a minimum thickness of 6 mil, and shall be keyed in at the top of slope and firmly held in place with sandbags or other weights placed no more than 3 m (10 ft) apart. Seams are typically taped or weighted down their entire length, and there shall be at least a 300 mm to 600 mm (12 to 24 inches) overlap of all seams. Edges shall be embedded a minimum of 150 mm (6 inches) in soil.
- All sheeting shall be inspected periodically after installation and after significant rainstorms to check for erosion, undermining, and anchorage failure. Any failures shall be repaired immediately. If washout or breakages occurs, the material shall be re-installed after repairing the damage to the slope.

Erosion Control Blankets/Mats

- Biodegradable rolled erosion control products (RECPs) are typically composed of jute fibers, curled wood fibers, straw, coconut fiber, or a combination of these materials. For an RECP to be considered 100% biodegradable, the netting, sewing or adhesive system that holds the biodegradable mulch fibers together must also be biodegradable.
 - **Jute** is a natural fiber that is made into a yarn, which is loosely woven into a biodegradable mesh. It is designed to be used in conjunction with vegetation and has longevity of approximately one year. The material is supplied in rolled strips, which shall be secured to the soil with U-shaped staples or stakes in accordance with manufacturers' recommendations.
 - **Excelsior (curled wood fiber)** blanket material shall consist of machine produced mats of curled wood excelsior with 80 percent of the fiber 150 mm (6 inches) or longer. The excelsior blanket shall be of consistent thickness. The wood fiber shall be evenly distributed over the entire area of the blanket. The top surface of the blanket shall be covered with a photodegradable extruded plastic mesh. The blanket shall be smolder resistant without the use of chemical additives and shall be non-toxic and non-injurious to plant and animal life. Excelsior blanket shall be furnished in rolled strips, a minimum of 1220 mm (48 inches) wide, and shall have an average weight of 0.5 kg/m² (12 lb/ft²), ±10 percent, at the time of manufacture. Excelsior blankets shall be secured in place with wire staples. Staples shall be made of 3.05-mm (0.12 inch) steel wire and shall be U-shaped with 200-mm (8-inch) legs and 50-mm (2-inch) crown.

- **Straw blanket** shall be machine-produced mats of straw with a lightweight biodegradable netting top layer. The straw shall be attached to the netting with biodegradable thread or glue strips. The straw blanket shall be of consistent thickness. The straw shall be evenly distributed over the entire area of the blanket. Straw blanket shall be furnished in rolled strips a minimum of 2 m (6.5 ft) wide, a minimum of 25 m (80 ft) long and a minimum of 0.27 kg/m² (6.4 lb/ft²). Straw blankets shall be secured in place with wire staples. Staples shall be made of 3.05-mm (0.12 inch) steel wire and shall be U-shaped with 200-mm (8-inch) legs and 50-mm (2-inch) crown.
- **Wood fiber blanket** is composed of biodegradable fiber mulch with extruded plastic netting held together with adhesives. The material is designed to enhance revegetation. The material is furnished in rolled strips, which shall be secured to the ground with U-shaped staples or stakes in accordance with manufacturers' recommendations.
- **Coconut fiber blanket** shall be machine-produced mats of 100% coconut fiber with biodegradable netting on the top and bottom. The coconut fiber shall be attached to the netting with biodegradable thread or glue strips. The coconut fiber blanket shall be of consistent thickness. The coconut fiber shall be evenly distributed over the entire area of the blanket. Coconut fiber blanket shall be furnished in rolled strips with a minimum of 2 m (6.5 ft) wide, a minimum of 25 m (80 ft) long and a minimum of 0.27-kg/m² (6.4 lb/ft²). Coconut fiber blankets shall be secured in place with wire staples. Staples shall be made of 3.05-mm (0.12 inch) steel wire and shall be U-shaped with 200-mm (8-inch) legs and 50-mm (2-inch) crown.
- **Coconut fiber mesh** is a thin permeable membrane made from coconut or corn fiber that is spun into a yarn and woven into a biodegradable mat. It is designed to be used in conjunction with vegetation and typically has longevity of several years. The material is supplied in rolled strips, which shall be secured to the soil with U-shaped staples or stakes in accordance with manufacturers' recommendations.
- **Straw coconut fiber blanket** shall be machine-produced mats of 70% straw and 30% coconut fiber with a biodegradable netting top layer and a biodegradable bottom net. The straw and coconut fiber shall be attached to the netting with biodegradable thread or glue strips. The straw coconut fiber blanket shall be of consistent thickness. The straw and coconut fiber shall be evenly distributed over the entire area of the blanket. Straw coconut fiber blanket shall be furnished in rolled strips a minimum of 2 m (6.5 ft) wide, a minimum of 25 m (80 ft) long and a minimum of 0.27 kg/m² (6.4 lb/ft²). Straw coconut fiber blankets shall be secured in place with wire staples. Staples shall be made of 3.05-mm (0.12-inch) steel wire and shall be U-shaped with 200-mm (8-inch) legs and 50-mm (2-inch) crown.

- Non-biodegradable RECPs are typically composed of polypropylene, polyethylene, nylon or other synthetic fibers. In some cases, a combination of biodegradable and synthetic fibers is used to construct the RECP. Netting used to hold these fibers together is typically non-biodegradable as well.
 - **Plastic netting** is a lightweight biaxially-oriented netting designed for securing loose mulches like straw to soil surfaces to establish vegetation. The netting is photodegradable. The netting is supplied in rolled strips, which shall be secured with U-shaped staples or stakes in accordance with manufacturers' recommendations.
 - **Plastic mesh** is an open-weave geotextile that is composed of an extruded synthetic fiber woven into a mesh with an opening size of less than 0.5 cm (0.2 inch). It is used with revegetation or may be used to secure loose fiber such as straw to the ground. The material is supplied in rolled strips, which shall be secured to the soil with U-shaped staples or stakes in accordance with manufacturers' recommendations.
 - **Synthetic fiber with netting** is a mat that is composed of durable synthetic fibers treated to resist chemicals and ultraviolet light. The mat is a dense, three-dimensional mesh of synthetic (typically polyolefin) fibers stitched between two polypropylene nets. The mats are designed to be revegetated and provide a permanent composite system of soil, roots, and geomatrix. The material is furnished in rolled strips, which shall be secured with U-shaped staples or stakes in accordance with manufacturers' recommendations.
 - **Bonded synthetic fibers** consist of a three-dimensional geomatrix nylon (or other synthetic) matting. Typically it has more than 90% open area, which facilitates root growth. Its tough root-reinforcing system anchors vegetation and protects against hydraulic lift and shear forces created by high volume discharges. It can be installed over prepared soil, followed by seeding into the mat. Once vegetated, it becomes an invisible composite system of soil, roots, and geomatrix. The material is furnished in rolled strips that shall be secured with U-shaped staples or stakes in accordance with manufacturers' recommendations.
 - **Combination synthetic and biodegradable RECPs** consist of biodegradable fibers, such as wood fiber or coconut fiber, with a heavy polypropylene net stitched to the top and a high-strength continuous-filament geomatrix or net stitched to the bottom. The material is designed to enhance revegetation. The material is furnished in rolled strips, which shall be secured with U-shaped staples or stakes in accordance with manufacturers' recommendations.

Site Preparation

- Proper site preparation is essential to ensure complete contact of the blanket or matting with the soil.
- Grade and shape the area of installation.
- Remove all rocks, clods, vegetation or other obstructions so that the installed blankets or mats will have complete, direct contact with the soil.
- Prepare seedbed by loosening 50 mm (2 in) to 75 mm (3 in) of topsoil.

Seeding

Seed the area before blanket installation for erosion control and revegetation. Seeding after mat installation is often specified for turf reinforcement application. When seeding prior to blanket installation, all check slots and other areas disturbed during installation must be re-seeded. Where soil filling is specified, seed the matting and the entire disturbed area after installation and prior to filling the mat with soil.

Anchoring

- U-shaped wire staples, metal geotextile stake pins or triangular wooden stakes can be used to anchor mats and blankets to the ground surface.
- Staples shall be made of 3.05 mm (0.12 inch) steel wire and shall be U-shaped with 200-mm (8-inch) legs and 50-mm (2-inch) crown.
- Metal stake pins shall be 5 mm (0.188 in) diameter steel with a 40 mm (1.5 in) steel washer at the head of the pin.
- Wire staples and metal stakes shall be driven flush to the soil surface.
- All anchors shall be 150 mm (6 in) to 450 mm (18 in) long and have sufficient ground penetration to resist pullout. Longer anchors may be required for loose soils.

Installation on Slopes

Installation shall be in accordance with the manufacturer's recommendations. In general, these will be as follows:

- Begin at the top of the slope and anchor the blanket in a 150 mm (6 in) deep by 150 mm (6 in) wide trench. Backfill trench and tamp earth firmly.
- Unroll blanket downslope in the direction of water flow.

- Overlap the edges of adjacent parallel rolls 50 mm (2 in) to 75 mm (3 in) and staple every 1 m (3 ft).
- When blankets must be spliced, place blankets end over end (shingle style) with 150 mm (6 in) overlap. Staple through overlapped area, approximately 300 mm (12 in) apart.
- Lay blankets loosely and maintain direct contact with the soil. Do not stretch.
- Staple blankets sufficiently to anchor blanket and maintain contact with the soil. Staples shall be placed down the center and staggered with the staples placed along the edges. Steep slopes, 1:1 (V:H) to 1:2 (V:H), require a minimum of 2 staples/m² (2 staples/yd²). Moderate slopes, 1:2 (V:H) to 1:3 (V:H), require a minimum of 1½ staples/m² (1 ½ staples/yd²), placing 1 staple/m (1 staple/yd) on centers. Gentle slopes require a minimum of 1 staple/m² (1 staple/yd²).

Installation in Channels

Installation shall be in accordance with the manufacturer's recommendations. In general, these will be as follows:

- Dig initial anchor trench 300 mm (12 in) deep and 150 mm (6 in) wide across the channel at the lower end of the project area.
- Excavate intermittent check slots, 150 mm (6 in) deep and 150 mm (6 in) wide across the channel at 8 m to 10 m (25 ft to 30 ft) intervals along the channels.
- Cut longitudinal channel anchor slots 100 mm (4 in) deep and 100 mm (4 in) wide along each side of the installation to bury edges of matting, whenever possible extend matting 50 mm (2 in) to 75 mm (3 in) above the crest of the channel side slopes.
- Beginning at the downstream end and in the center of the channel, place the initial end of the first roll in the anchor trench and secure with fastening devices at 300 mm (12 in) intervals. Note: matting will initially be upside down in anchor trench.
- In the same manner, position adjacent rolls in anchor trench, overlapping the preceding roll a minimum of 75 mm (3 in).
- Secure these initial ends of mats with anchors at 300 mm (12 in) intervals, backfill and compact soil.
- Unroll center strip of matting upstream. Stop at next check slot or terminal anchor trench. Unroll adjacent mats upstream in similar fashion, maintaining a 75 mm (3 in) overlap.

- Fold and secure all rolls of matting snugly into all transverse check slots. Lay mat in the bottom of the slot then fold back against itself. Anchor through both layers of mat at 300 mm (12 in) intervals, then backfill and compact soil. Continue rolling all mat widths upstream to the next check slot or terminal anchor trench.
- Alternate method for non-critical installations: Place two rows of anchors on 150 mm (6 in) centers at 8 m (25 ft) to 10 m (30 ft) intervals in lieu of excavated check slots.
- Shingle-lap spliced ends by a minimum of 300 mm (12 in) apart on 300 mm (12 in) intervals.
- Place edges of outside mats in previously excavated longitudinal slots, anchor using prescribed staple pattern, backfill and compact soil.
- Anchor, fill and compact upstream end of mat in a 300 mm (12 in) by 150 mm (6 in) terminal trench.
- Secure mat to ground surface using U-shaped wire staples, geotextile pins, or wooden stakes.
- Seed and fill turf reinforcement matting with soil, if specified.

Soil Filling (if specified for turf reinforcement)

- Always consult the manufacturer's recommendations for installation.
- Do not drive tracked or heavy equipment over mat.
- Avoid any traffic over matting if loose or wet soil conditions exist.
- Use shovels, rakes or brooms for fine grading and touch up.
- Smooth out soil filling, just exposing top netting of mat.

Temporary Soil Stabilization Removal

- When no longer required for the work, temporary soil stabilization shall become the property of the Contractor. Temporary soil stabilization removed from the site of the work shall be disposed of outside the highway right-of-way in conformance with the provisions in Standard Specifications Section 7-1.13. If approved by the RE, the contractor may leave the temporary soil stabilizer in place.

Geotextiles, Mats, Plastic Covers and Erosion Control Blankets

SS-7

Maintenance and Inspection

Areas treated with temporary soil stabilization shall be inspected as specified in the special provisions. Areas treated with temporary soil stabilization shall be maintained to provide adequate erosion control. Temporary soil stabilization shall be reapplied or replaced on exposed soils when area becomes exposed or exhibits visible erosion.

- All blankets and mats shall be inspected periodically after installation.
- Installation shall be inspected after significant rain storms to check for erosion and undermining. Any failures shall be repaired immediately.
- If washout or breakage occurs, re-install the material after repairing the damage to the slope or channel.



Typical Installation Detail

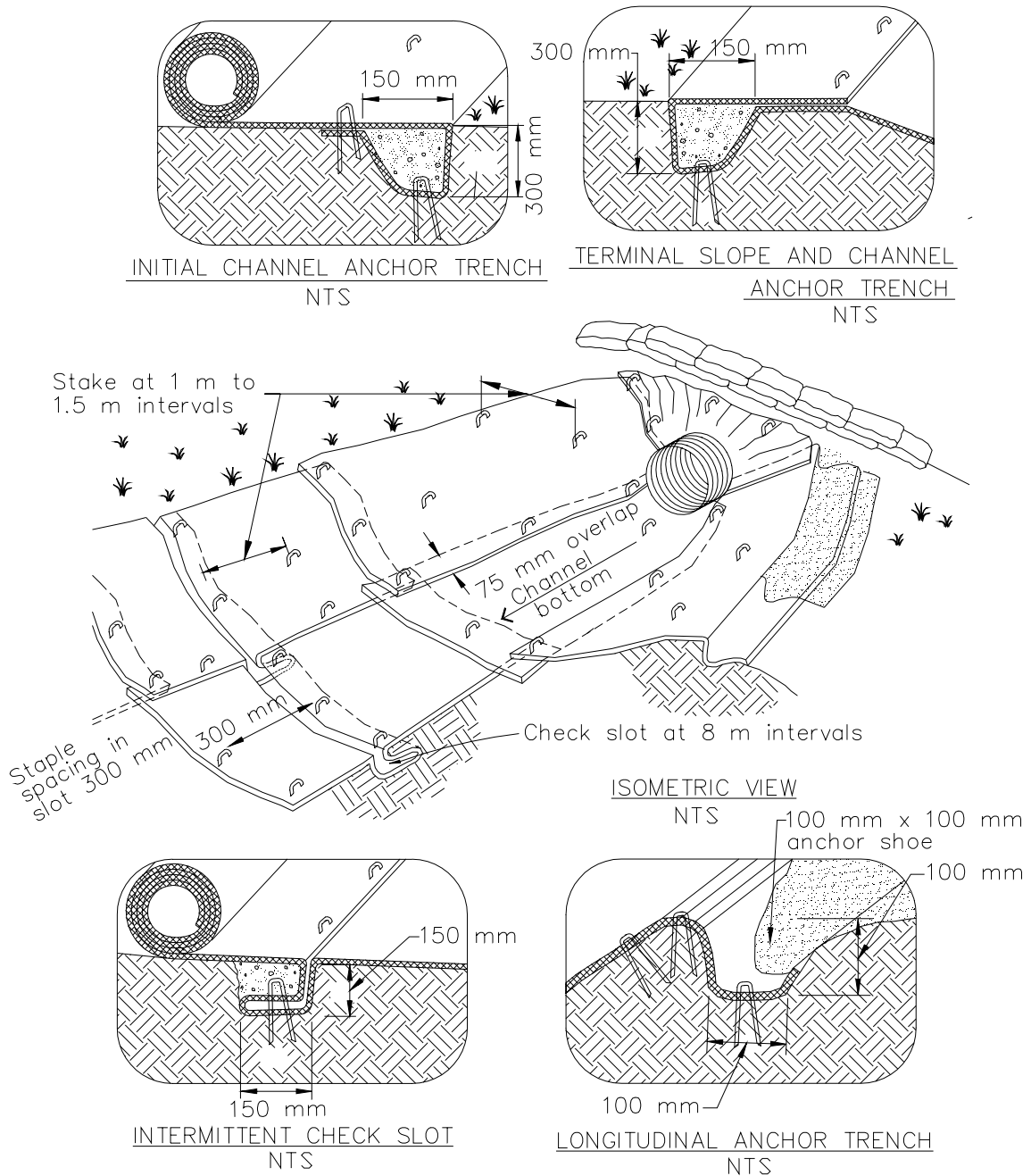

NOTES:

1. Check slots to be constructed per manufacturers specifications.
2. Staking or stapling layout per manufacturers specifications.
3. Install per manufacturer's recommendations

Typical Installation Detail

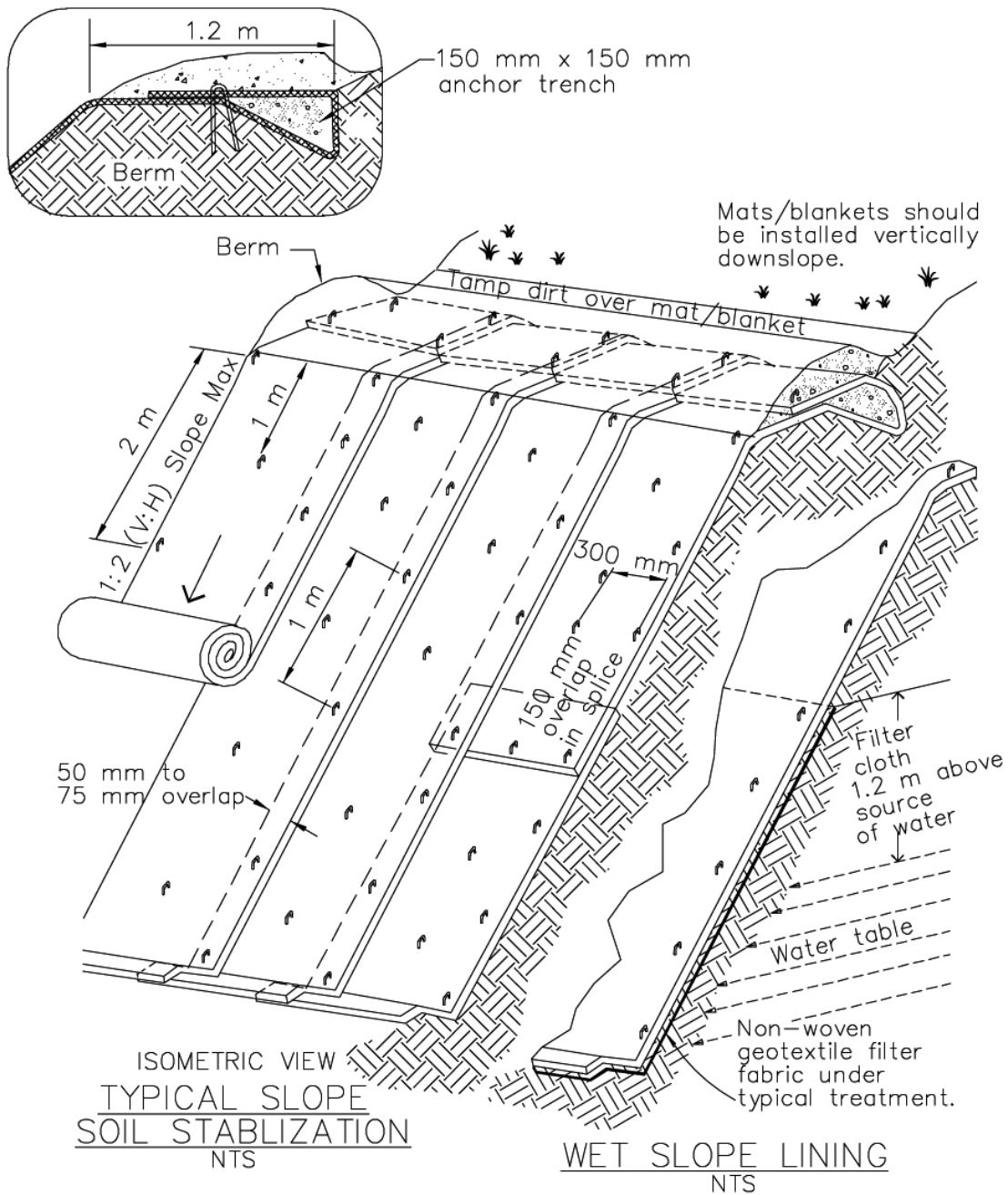

NOTES:

1. Slope surface shall be free of rocks, clods, sticks and grass. Mats/blankets shall have good soil contact.
2. Lay blankets loosely and stake or staple to maintain direct contact with the soil. Do not stretch.
3. Install per manufacturer's recommendations

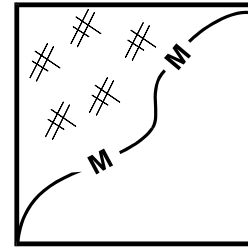

Standard Symbol

BMP Objectives

- Soil Stabilization
- Sediment Control
- Tracking Control
- Wind Erosion Control
- Non-Storm Water Management
- Materials and Waste Management

Definition and Purpose Wood mulching consist of applying a mixture of shredded wood mulch, bark or compost. Wood mulch is mostly applicable to landscape projects.

The primary function of wood mulching is to reduce erosion by protecting bare soil from rainfall impact, increasing infiltration, and reducing runoff.

Appropriate Applications Wood mulching is considered a temporary soil stabilization (erosion control) alternative in the following situations:

- As a stand-alone temporary surface cover on disturbed areas until soils can be prepared for revegetation and permanent vegetative cover can be established.
- As short term, non-vegetative ground cover on slopes to reduce rainfall impact, decrease the velocity of sheet flow, settle out sediment and reduce wind erosion.

- Limitations**
- Wood mulch may introduce unwanted species.
 - Shredded wood does not withstand concentrated flows and is prone to sheet erosion.
 - Green material has the potential for the presence of unwanted weeds and other plant materials. Delivery system is primarily by manual labor, although pneumatic application equipment is available.

Standards and Specifications

Mulch Selection

There are many types of mulches, and selection of the appropriate type shall be based on the type of application and site conditions. Prior to use of wood mulches, there shall be concurrence with the District Landscape Architect since some mulch use on construction projects may not be compatible with planned or future projects. Selection of wood mulches by the Contractor shall comply with Standard Specifications Section 20-2.08, and must be approved by the Resident Engineer (RE).

Application Procedures

Prior to application, after existing vegetation has been removed, roughen embankment and fill areas by rolling with a punching-type roller or by track walking. The construction-application procedures for mulches vary significantly depending upon the type of mulching method specified. Two (2) methods are highlighted here:

- **Green Material:** This type of mulch is produced by recycling vegetation trimmings such as grass, shredded shrubs and trees. Methods of application are generally by hand, although pneumatic methods are available. Mulch shall be composted to kill weed seeds.
 - It can be used as a temporary ground cover with or without seeding.
 - The green material shall be evenly distributed on site to a depth of not more than 50 mm (2 in).
- **Shredded Wood:** Suitable for ground cover in ornamental or revegetated plantings.
 - Shredded wood/bark is conditionally suitable; see note under limitations.
 - Shall be distributed by hand (although pneumatic methods may be available).
 - The mulch shall be evenly distributed across the soil surface to a depth of 50 mm (2 in) to 75 mm (3 in).
- Avoid mulch placement onto the traveled way, sidewalks, lined drainage channels, sound walls, and existing vegetation.
- All material must be removed before re-starting work on the slopes.

Maintenance and Inspection

- Regardless of the mulching technique selected, the key consideration in Maintenance and Inspection is that the mulch needs to last long enough to achieve erosion-control objectives. If the mulch is applied as a stand-alone erosion control method over disturbed areas (without seed), it shall last the length of time the site will remain barren or until final re-grading and revegetation.
- Where vegetation is not the ultimate cover, such as ornamental and landscape applications of bark or wood chips, inspection and maintenance shall focus on longevity and integrity of the mulch.

Earth Dikes/Drainage Swales and Lined Ditches

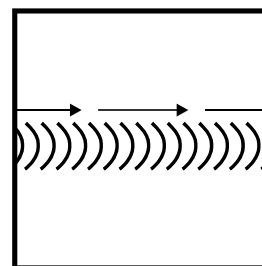
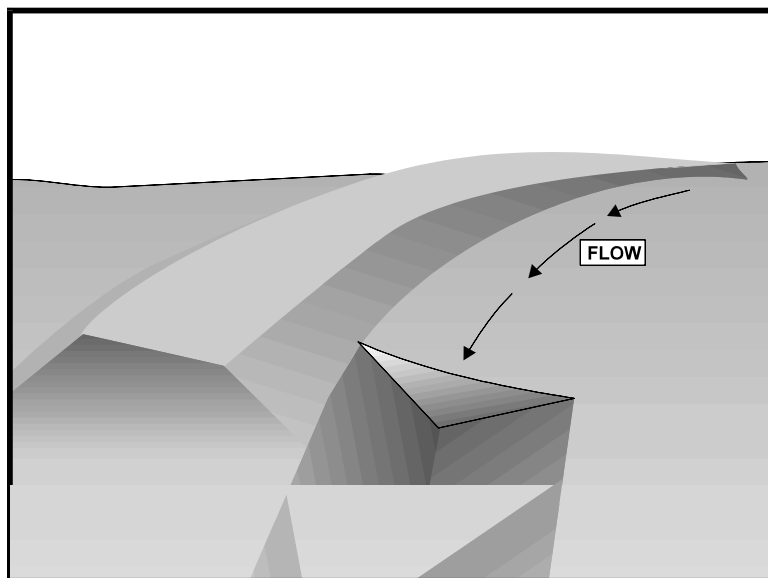

Standard Symbol

- BMP Objectives**
- Soil Stabilization
 - Sediment Control
 - Tracking Control
 - Wind Erosion Control
 - Non-Storm Water Management
 - Materials and Waste Management

Definition and Purpose

These are structures that intercept, divert and convey surface run-on, generally sheet flow, to prevent erosion.

Appropriate Applications

- Earth dikes/drainage swales and lined ditches may be used to:
 - Convey surface runoff down sloping land.
 - Intercept and divert runoff to avoid sheet flow over sloped surfaces.
 - Divert and direct runoff towards a stabilized watercourse, drainage pipe or channel.
 - Intercept runoff from paved surfaces.
- Earth dikes/drainage swales and lined ditches also may be used:
 - Below steep grades where runoff begins to concentrate.
 - Along roadways and facility improvements subject to flood drainage.
 - At the top of slopes to divert run-on from adjacent or undisturbed slopes.
 - At bottom and mid-slope locations to intercept sheet flow and convey concentrated flows.
- This BMP may be implemented on a project-by-project basis with other BMPs when determined necessary and feasible by the Resident Engineer (RE).

Earth Dikes/Drainage Swales and Lined Ditches

SS-9

- Limitations**
- Earth dikes/drainage swales and lined ditches are not suitable as sediment trapping devices.
 - May be necessary to use other soil stabilization and sediment controls, such as check dams, plastics, and blankets, to prevent scour and erosion in newly graded dikes, swales and ditches.
- Standards and Specifications**
- Care must be applied to correctly size and locate earth dikes, drainage swales and lined ditches. Excessively steep, unlined dikes and swales are subject to erosion and gully formation.
 - Conveyances shall be stabilized.
 - Use a lined ditch for high flow velocities.
 - Select flow velocity based on careful evaluation of the risks due to erosion of the measure, soil types, over topping, flow backups, washout, and drainage flow patterns for each project site.
 - Compact any fills to prevent unequal settlement.
 - Do not divert runoff from the highway right-of-way onto other property.
 - When possible, install and utilize permanent dikes, swales and ditches early in the construction process.
 - Provide stabilized outlets. Refer to SS-10, “Outlet Protection/Velocity/Dissipation Devices.”
- Maintenance and Inspections**
- Inspect temporary measures prior to the rainy season, after rainfall events, and regularly (approximately once per week) during the rainy season.
 - Inspect ditches and berms for washouts. Replace lost riprap, damaged linings or soil stabilizers as needed.
 - Inspect channel linings, embankments, and beds of ditches and berms for erosion and accumulation of debris and sediment. Remove debris and sediment, and repair linings and embankments as needed or as directed by the RE.
 - Temporary conveyances shall be completely removed as soon as the surrounding drainage area has been stabilized, or at the completion of construction.

Earth Dikes/Drainage Swales and Lined Ditches

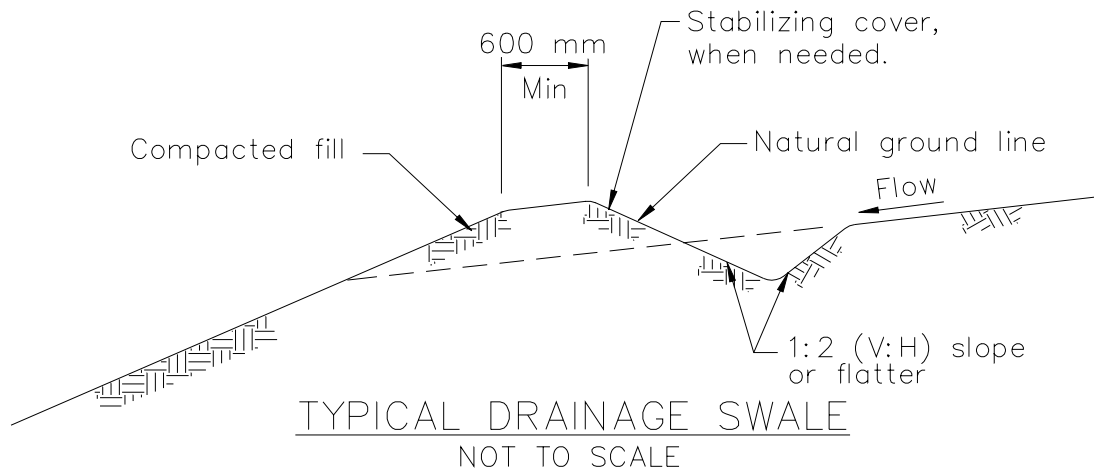

NOTES:

1. Stabilize inlet, outlets and slopes.
2. Properly compact the subgrade, in conformance with Section 19-5 of the Caltrans Standard Specifications.

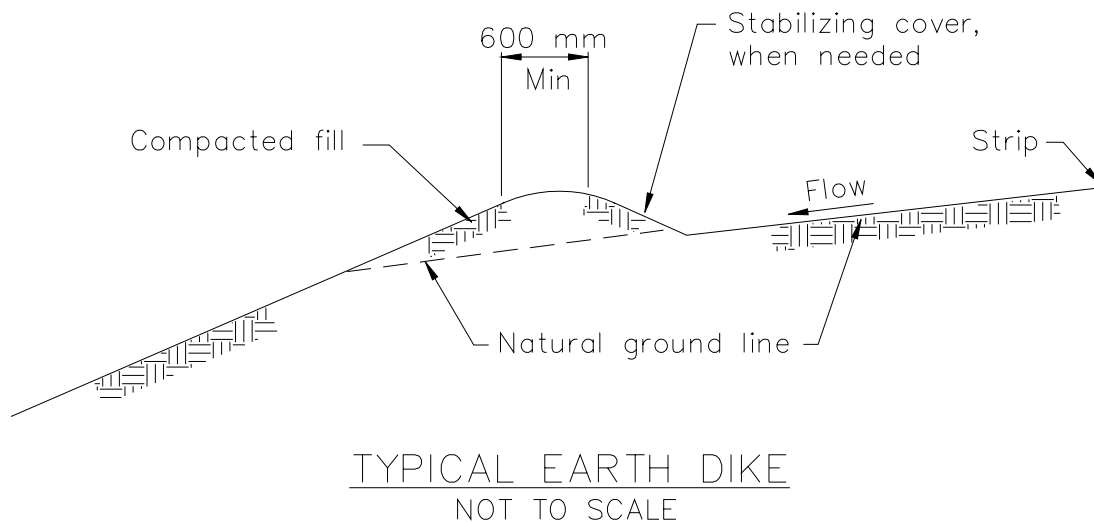

Outlet Protection/Velocity Dissipation Devices

SS-10

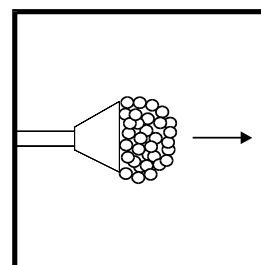
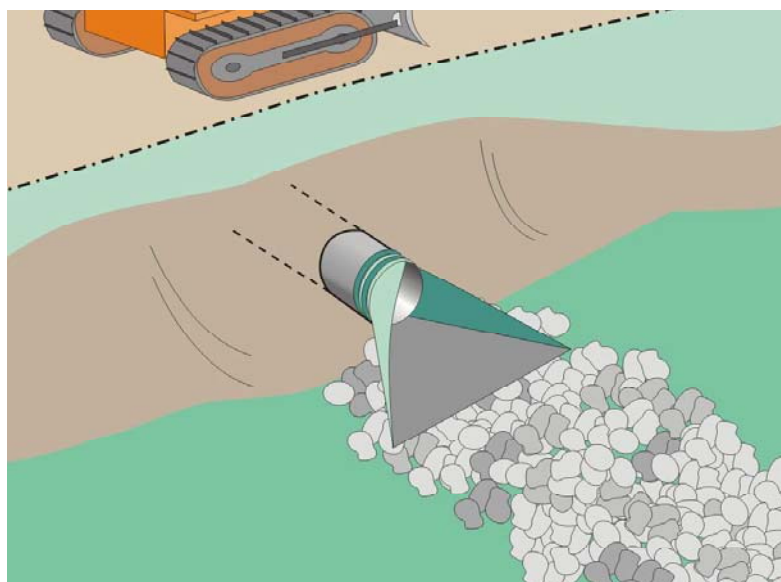

Standard Symbol

BMP Objectives

- Soil Stabilization
- Sediment Control
- Tracking Control
- Wind Erosion Control
- Non-Storm Water Management
- Materials and Waste Management

Definition and Purpose These devices are placed at pipe outlets to prevent scour and reduce the velocity and/or energy of storm water flows.

Appropriate Applications

- These devices may be used at the following locations:
 - Outlets of pipes, drains, culverts, slope drains, diversion ditches, swales, conduits or channels.
 - Outlets located at the bottom of mild to steep slopes.
 - Discharge outlets that carry continuous flows of water.
 - Outlets subject to short, intense flows of water, such as flash floods.
 - Points where lined conveyances discharge to unlined conveyances.
- This BMP may be implemented on a project-by-project basis with other BMPs when determined necessary and feasible by the Resident Engineer (RE).

Limitations

- Loose rock may have stones washed away during high flows.
- Grouted riprap may break up in areas of freeze and thaw.
- If there is not adequate drainage, and water builds up behind grouted riprap, it may cause the grouted riprap to break up due to the resulting hydrostatic pressure.

Outlet Protection/Velocity Dissipation Devices

SS-10

- Standards and Specifications**
- There are many types of energy dissipaters, with rock being the one that is represented in the figure on Page 3. Please note that this is only one example and the RE may approve other types of devices proposed by the contractor.
 - Install riprap, grouted riprap, or concrete apron at selected outlet. Riprap aprons are best suited for temporary use during construction.
 - Carefully place riprap to avoid damaging the filter fabric.
 - For proper operation of apron:
 - Align apron with receiving stream and keep straight throughout its length. If a curve is needed to fit site conditions, place it in upper section of apron.
 - If size of apron riprap is large, protect underlying filter fabric with a gravel blanket.
 - Outlets on slopes steeper than 10% shall have additional protection.
- Maintenance and Inspection**
- Inspect temporary measures prior to the rainy season, after rainfall events, and regularly (approximately once per week) during the rainy season.
 - Inspect apron for displacement of the riprap and/or damage to the underlying fabric. Repair fabric and replace riprap that has washed away.
 - Inspect for scour beneath the riprap and around the outlet. Repair damage to slopes or underlying filter fabric immediately.
 - Temporary devices shall be completely removed as soon as the surrounding drainage area has been stabilized, or at the completion of construction.

Outlet Protection/Velocity Dissipation Devices

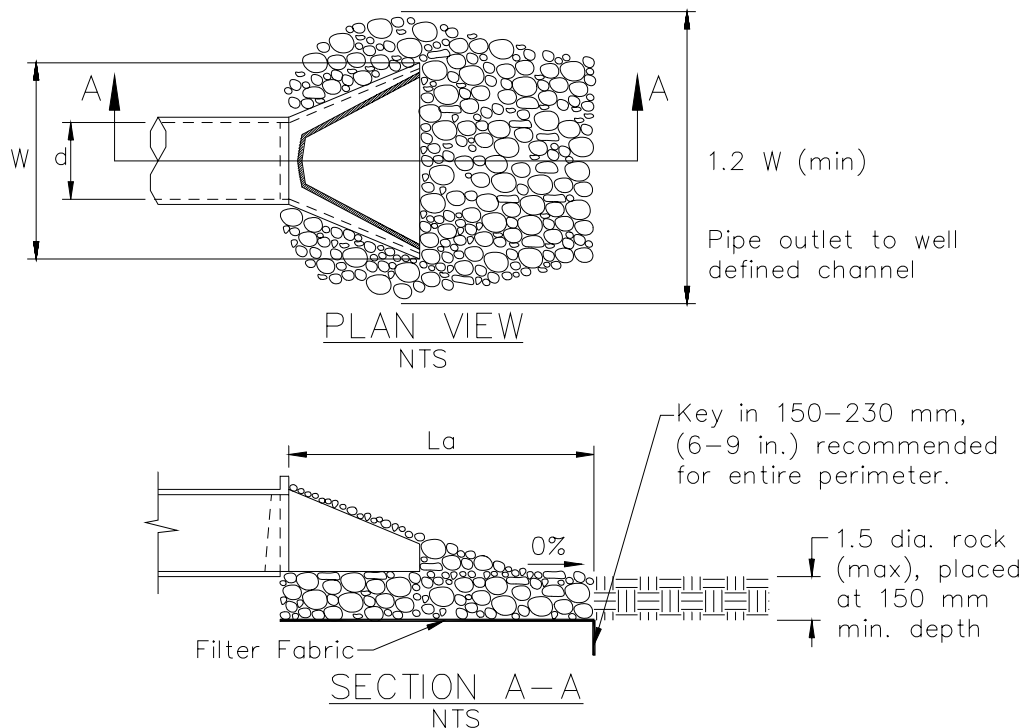

Pipe Diameter mm	Discharge m ³ /s	Apron Length, La m	Rip Rap D ₅₀ Diameter Min mm
300	0.14	3	100
	0.28	4	150
450	0.28	3	150
	0.57	5	200
	0.85	7	300
	1.13	8	400
600	0.85	5	200
	1.13	8	200
	1.42	8	300
	1.70	9	400

For larger or higher flows, consult a Registered Civil Engineer

Source: USDA – SCS

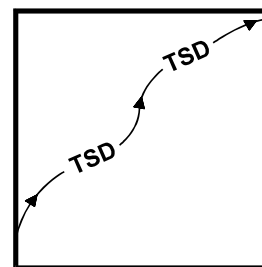
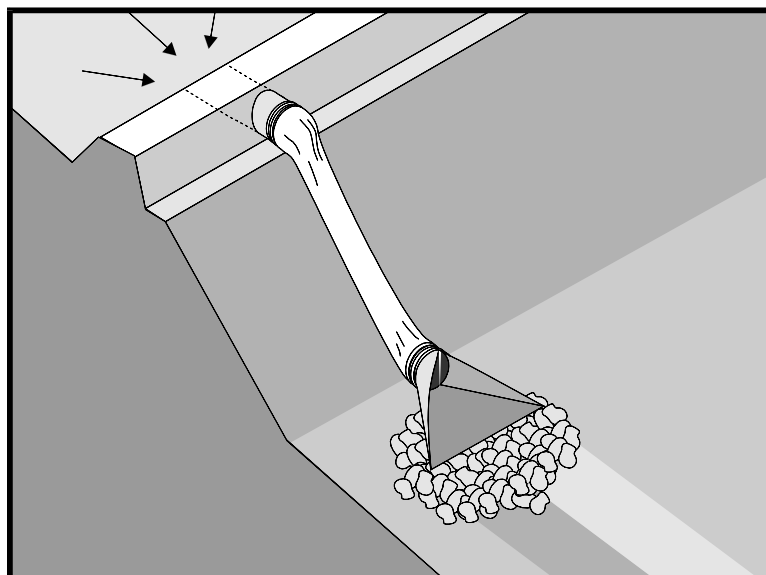

Standard Symbol

BMP Objectives

- Soil Stabilization
- Sediment Control
- Tracking Control
- Wind Erosion Control
- Non-Storm Water Management
- Materials and Waste Management

Definition and Purpose A slope drain is a pipe used to intercept and direct surface runoff or groundwater into a stabilized watercourse, trapping device or stabilized area. Slope drains are used with lined ditches to intercept and direct surface flow away from slope areas to protect cut or fill slopes.

Appropriate Applications

- Slope drains may be used on construction sites where slopes may be eroded by surface runoff.
- This BMP may be implemented on a project-by-project basis with other BMPs when determined necessary and feasible by the Resident Engineer (RE).

Limitations

- Severe erosion may result when slope drains fail by overtopping, piping, or pipe separation.

Standards and Specifications

- When using slope drains, limit drainage area to 4 ha (10 ac) per pipe. For larger areas, use a rock-lined channel or a series of pipes.
- Maximum slope generally limited to 1:2 (V:H), as energy dissipation below steeper slopes is difficult.
- Direct surface runoff to slope drains with interceptor dikes. See BMP SS-8, "Earth Dikes/Drainage Swales, and Lined Ditches."
- Slope drains can be placed on or buried underneath the slope surface.
- Recommended materials are PVC, ABS, or comparable pipe.
- When installing slope drains:
 - Install slope drains perpendicular to slope contours.

- Compact soil around and under entrance, outlet, and along length of pipe.
- Securely anchor and stabilize pipe and appurtenances into soil.
- Check to ensure that pipe connections are water tight.
- Protect area around inlet with filter cloth. Protect outlet with riprap or other energy dissipation device. For high energy discharges, reinforce riprap with concrete or use reinforced concrete device.
- Protect inlet and outlet of slope drains; use standard flared end section at entrance and exit for pipe slope drains 300 mm (12in) and larger.

Maintenance and Inspection

- Inspect before and after each rain storm, and twice monthly until the tributary drainage area has been stabilized. Follow routine inspection procedures for inlets thereafter.
- Inspect outlet for erosion and downstream scour. If eroded, repair damage and install additional energy dissipation measures. If downstream scour is occurring, it may be necessary to reduce flows being discharged into the channel unless other preventative measures are implemented.
- Inspect slope drainage for accumulations of debris and sediment.
- Remove built-up sediment from entrances, outlets, and within drains as required.
- Make sure water is not ponding onto inappropriate areas (e.g., active traffic lanes, material storage areas, etc.).

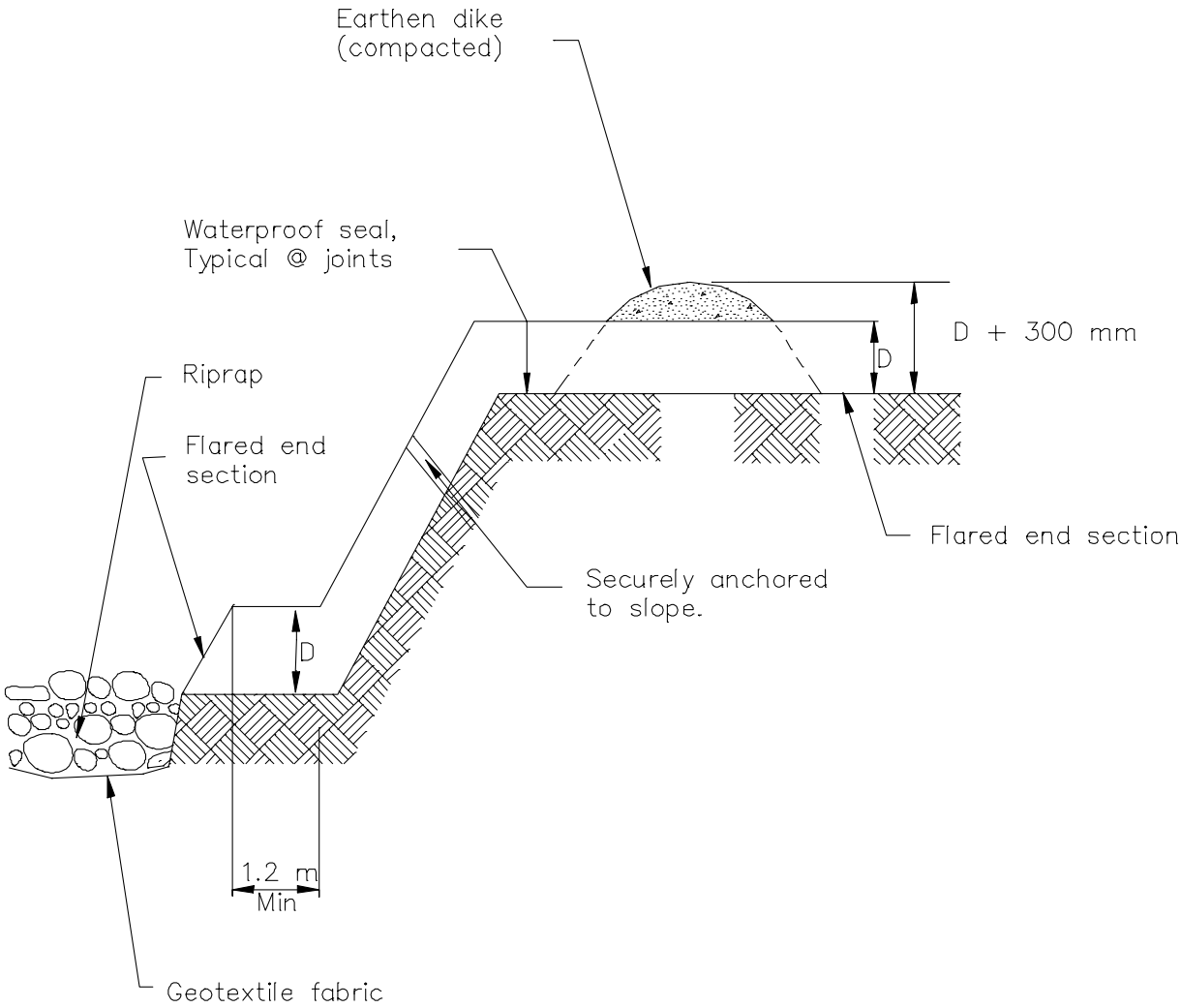

TYPICAL SLOPE DRAIN
NOT TO SCALE



Standard Symbol

- BMP Objectives**

 - Soil Stabilization
 - Sediment Control
 - Tracking Control
 - Wind Erosion Control
 - Non-Storm Water Management
 - Materials and Waste Management

Definition and Purpose Drainage systems including the stream channel, streambank, and associated riparian areas, are dynamic and sensitive ecosystems that respond to changes in land use activity. Streambank and channel disturbance resulting from construction activities can increase the stream’s sediment load, which can cause channel erosion or sedimentation and have adverse affects on the biotic system. Best Management Practices can reduce the discharge of sediment and other pollutants and minimize the impact of construction activities on watercourses. Streams included on the 303(d) list by the State Water Resources Control Board (SWRCB) may require careful evaluation to prevent any increases in sedimentation, siltation and/or turbidity to the stream.

Appropriate Applications These procedures typically apply to all construction projects that disturb or occur within stream channels and their associated riparian areas.

Limitations Specific permit requirements or mitigation measures such as Regional Water Quality Control Board (RWQCB) 401 Certification, U.S. Army Corps of Engineers 404 permit and approval by California Department of Fish and Game may be included in contract documents. If numerical-based water quality standards are mentioned in any of these and other related permits, testing and sampling may be required. Streams included on the 303(d) list by the State Water Resources Control Board because of being impaired by sediment, silt, or turbidity are required to conduct sampling to verify that there is no net increase in sediment load due to construction activities.

Standards and Specifications **PLANNING**

- Proper planning, design, and construction techniques can minimize impacts normally associated with in-stream construction activities. Poor planning can adversely affect soil, fish, and wildlife resources, land uses, or land users. Planning should take into account: scheduling, avoidance of in-stream construction; minimizing disturbance area and construction time period; using

pre-disturbed areas; selecting crossing location; and selecting equipment.

Scheduling (SS-1)

- Construction activities should be scheduled according to the relative sensitivity of the environmental concerns and in accordance with SS-1, “Scheduling.” Scheduling considerations will be different when working near perennial streams vs. ephemeral streams and are as follows:
 - Construction work near perennial streams should optimally be performed during the dry season (see below).
 - When working in or near ephemeral, intermittent, or perennial streams, construction should be performed during the dry season. By their very nature, ephemeral and intermittent streams are usually dry in the summer, and therefore, in-stream construction activities will not cause significant water quality problems. However, when closing the site at the end of the project, wash any fines (see Washing Fines) that were formed in-situ back into the channel the bed material, to decrease pollution from the first rainstorm (“first flush”) of the season. When working near stream channels, erosion and sediment controls (see silt fences, straw bale barriers, etc.) should be implemented on the banks to keep sediment out of stream channel proper.

Minimize Disturbance

- Minimize disturbance through: selection of the narrowest crossing location; limiting the number of equipment trips across a stream during construction; and, minimizing the number and size of work areas (equipment staging areas and spoil storage areas). Place work areas at least 15 m (50 ft) from the stream channel. Provide stabilized access to the stream when in-stream work is required. Field reconnaissance should be conducted during the planning stage to identify work areas.

Use of Pre-Disturbed Areas

- Locate project sites and work areas in pre-disturbed areas when possible.

Selection of Project Site

- Avoid steep and unstable banks, highly erodible or saturated soils, or highly fractured rock.
- Select project site that minimizes disturbance to aquatic species or habitat.

Equipment Selection

- Select equipment that reduces the amount of pressure exerted on the ground surface, and therefore, reduces erosion potential and/or use overhead or aerial access for transporting equipment across drainage channels. Use equipment that exerts ground pressures of less than 5 or 6 pounds per square inch (PSI), where possible. Low ground pressure equipment includes: wide or high

flotation tires (860 to 1850 mm [34 to 72 in] wide); dual tires; bogie axle systems; tracked machines; lightweight equipment; and, central tire inflation systems.

STREAMBANK STABILIZATION

Preservation of Existing Vegetation (SS-2)

- Preserve existing vegetation in accordance with SS-2, “Preservation of Existing Vegetation.” In a streambank environment preservation of existing vegetation provides the following benefits:

Water Quality Protection:

Vegetated buffers on slopes trap sediment and promote groundwater recharge. The buffer width needed to maintain water quality ranges from 5 to 30 m (16 to 98 ft). On gradual slopes, most of the filtering occurs within the first 10 m (33 ft). Steeper slopes require a greater width of vegetative buffer to provide water quality benefits.

Streambank Stabilization:

The root system of riparian vegetation stabilizes streambanks by increasing tensile strength in the soil. The presence of vegetation modifies the moisture condition of slopes (infiltration, evapotranspiration, interception) and increases bank stability.

Riparian Habitat

Buffers of diverse riparian vegetation provide food and shelter for riparian and aquatic organisms. Minimizing impacts to fisheries habitat is a major concern when working near streams and rivers. Riparian vegetation provides shade, shelter, organic matter (leaf detritus and large woody debris), and other nutrients that are necessary for fish and other aquatic organisms. Buffer widths for habitat concerns are typically wider than those recommended for water quality concerns (30 to 500 m [98 to 1,640 ft]).

When working near watercourses, it is important to understand the work site’s placement in the watershed. Riparian vegetation in the headwater streams has a greater impact on overall water quality than vegetation in downstream reaches. Preserving existing vegetation upstream is necessary to maintain water quality, minimize bank failure, and maximize riparian habitat downstream of the work site.

Limitations:

- Local county and municipal ordinances regarding width, extent and type of vegetative buffer required may exceed the specifications provided here; these ordinances should be investigated prior to construction.

Streambank Stabilization Specific Installation:

- As a general rule, the width of a buffer strip between a road and the stream is

recommended to be 15 m (48 ft) plus four times the percent slope of the land, measured between the road and the top of stream bank.

Hydraulic Mulch (SS-3)

- Apply hydraulic mulch on disturbed streambanks above the mean high water level in accordance with SS-3, “Hydraulic Mulch” to provide temporary soil stabilization.

Limitations

- Do not place hydraulic mulch or tackifiers below the mean high water level, as these materials could wash into the channel and impact water quality or possibly cause eutrophication.

Hydroseeding (SS-4)

- Hydroseed disturbed streambanks in accordance with SS-4, “Hydroseeding.”

Limitations

- Do not place tackifiers or fertilizers below the mean high water level, as these materials could wash into the channel and impact water quality or possibly cause eutrophication.

Soil Binders (SS-5)

- Apply soil binders to disturbed streambanks in accordance with SS-5, “Soil Binders.”

Limitations

- Do not place soil binders below the mean high water level. Soil binder must be environmentally benign and non-toxic to aquatic organisms.

Straw Mulch (SS-6)

- Apply straw mulch to disturbed streambanks in accordance with SS-6, “Straw Mulch.”

Limitations

- Do not place straw mulch below the mean high water level, as this material could wash into the channel and impact water quality or possibly cause eutrophication.

Geotextiles, Plastic Covers, & Erosion Control Blankets/Mats (SS-7)

- Install geotextiles, erosion control blankets and plastic as described in SS-7, “Geotextiles, Plastic Covers, & Erosion Control Blankets/Mats” to stabilize disturbed channels and streambanks. Not all applications should be in the channel, for example, certain geotextile netting may snag fish gills and are not appropriate in fish-bearing streams. Geotextile fabrics that are not biodegradable are not appropriate for in-stream use. Additionally, geotextile fabric or blankets placed in channels must be adequate to sustain anticipated

hydraulic forces.

Earth Dikes/Drainage Swales, and Lined Ditches (SS-9)

- Convey, intercept, or divert runoff from disturbed streambanks using SS-9, “Earth Dikes/Drainage Swales, and Lined Ditches.”

Limitations

- Do not place earth dikes in watercourses, as these structures are only suited for intercepting sheet flow, and should not be used to intercept concentrated flow.
- Place appropriately sized outlet protection and energy dissipation in accordance with SS-10, “Outlet Protection/Velocity Dissipation Devices.”

Outlet Protection/Velocity Dissipation Devices (SS-10)

- Place outlet protection or velocity dissipation devices at outlets of pipes, drains, culverts, slope drains, diversion ditches, swales, conduits or channels in accordance with SS-10.

Slope Drains (SS-11)

- Use slope drains to intercept and direct surface runoff or groundwater into a stabilized watercourse, trapping device or stabilized area in accordance with SS-11, “Slope Drains.”

Limitations

- Appropriately sized outlet protection/velocity dissipation devices must be placed at outlets to minimize erosion and scour.

STREAMBANK SEDIMENT CONTROL

Silt Fences (SC-1)

- Install silt fences in accordance with SC-1, “Silt Fence” to control sediment. Silt fences should only be installed where sediment-laden water can pond, thus allowing the sediment to settle out.

Fiber Rolls (SC-5)

- Install fiber rolls in accordance with SC-5, “Fiber Rolls” along slope contour above the high water level to intercept runoff, reduce flow velocity, release the runoff as sheet flow and provide removal of sediment from the runoff. In a stream environment, fiber rolls should be used in conjunction with other sediment control methods such as SC-1, “Silt Fence” or SC-9, “Straw Bale Barrier.” Install silt fence, straw bale barrier, or other erosion control methods along the toe of slope above the high water level.

Gravel Bag Berm (SC-6)

- A gravel bag berm or barrier can be utilized to intercept and slow the flow of sediment-laden sheet flow runoff in accordance with SC-6, “Gravel Bag Berm.” In a stream environment gravel bag barriers can allow sediment to settle from runoff before water leaves the construction site and can be used to isolate the work area from the stream.

Limitations:

- Gravel bag barriers are not recommended as a perimeter sediment control practice around streams.

Straw Bale Barrier (SC-9)

- Install straw bale barriers in accordance with SC-9, “Straw Bale Barrier” to control sediment. Straw bale barriers should only be installed where sediment-laden water can pond, thus allowing the sediment to settle out. Install a silt fence in accordance with SC-1, “Silt Fence” on the down-slope side of the straw bale barrier closest to stream channel to provide added sediment control.

Rock Filter

Description and Purpose:

- Rock filters are temporary erosion-control barriers composed of rock that is anchored in place. Rock filters detain the sediment-laden runoff, retain the sediment, and release the water as sheet flow at a reduced velocity. Typical rock filter installations are illustrated at the end of this Section.

Applications:

- Near the toe of slopes that may be subject to flow and rill erosion.

Limitations:

- Inappropriate for drainage areas greater than 2 ha (5 ac).
- Requires sufficient space for ponded water.
- Ineffective for diverting runoff because filters allow water to slowly seep through.
- Rock filter berms are difficult to remove when construction is complete.
- Unsuitable in developed areas or locations where esthetics is a concern.

Specifications:

- Rock: open-graded rock, 19 to 125 mm (0.75 to 5 inches) for concentrated flow applications.
- Woven wire sheathing: 25 mm (1 inch) diameter, hexagonal mesh, galvanized

20-gauge (used with rock filters in areas of concentrated flow).

- In construction traffic areas, maximum rock berm heights should be 300 mm (12 in). Berms should be constructed every 90 m (300 ft) on slopes less than 5:100 (V:H) (5%), every 60 m (200 ft) on slopes between 5:100 (V:H) (5%) and 10:100 (V:H) (10%), and every 30 m (100 ft) on slopes greater than 10:100 (V:H) (10%).

Maintenance and Inspection:

- Inspect berms before and after each significant rainfall event and weekly throughout the rainy season.
- Reshape berms as needed and replace lost or dislodged rock, and/or filter fabric.
- Inspect for sediment accumulation, remove sediment when depth reaches one-third of the berm height or 300 mm (12 in), whichever occurs first.

K-rail

Description and Purpose:

- This is temporary sediment control that uses K-rails to form the sediment deposition area, or to isolate the near-bank construction area. Install K-rails at toe of slope in accordance with procedures described in NS-5, "Clear Water Diversion."
- Barriers are placed end-to-end in a pre-designed configuration and gravel-filled bags are used at the toe of the barrier and also at their abutting ends to seal and prevent movement of sediment beneath or through the barrier walls.

Appropriate Applications:

- This technique is useful at the toe of embankments, cut or fill slopes.

Limitations:

- The K-rail method is not watertight and its proper use should be considered accordingly.

Inspection and Maintenance

- Inspect BMPs daily during construction.
- Maintain and repair BMPs.
- Remove accumulated sediment as necessary.

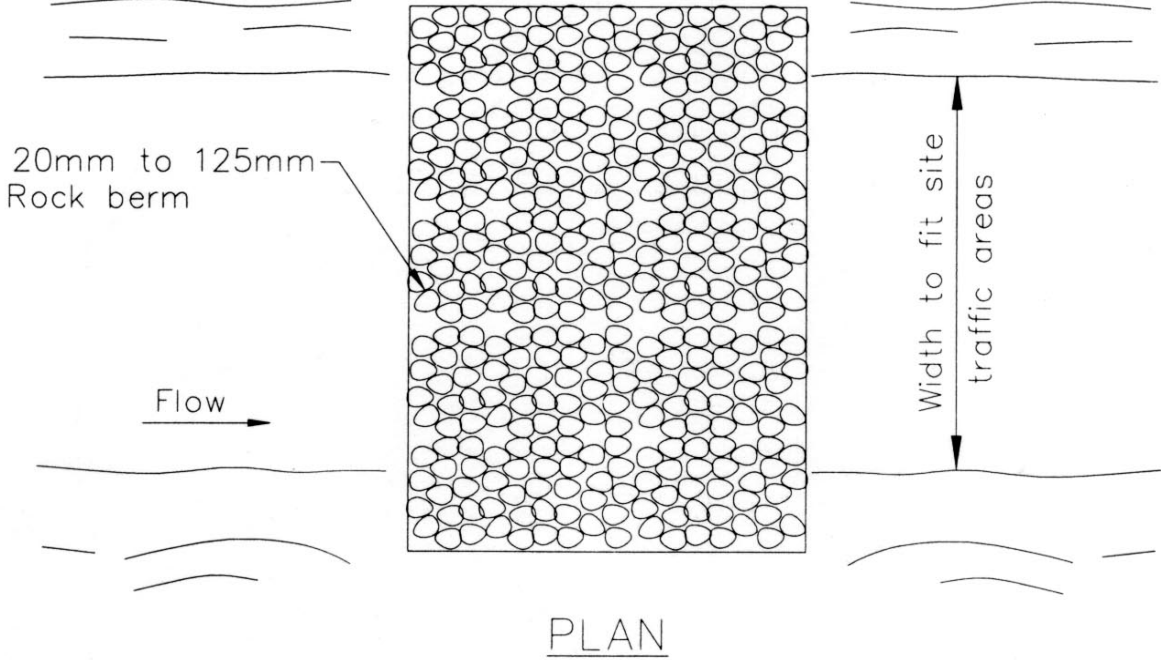
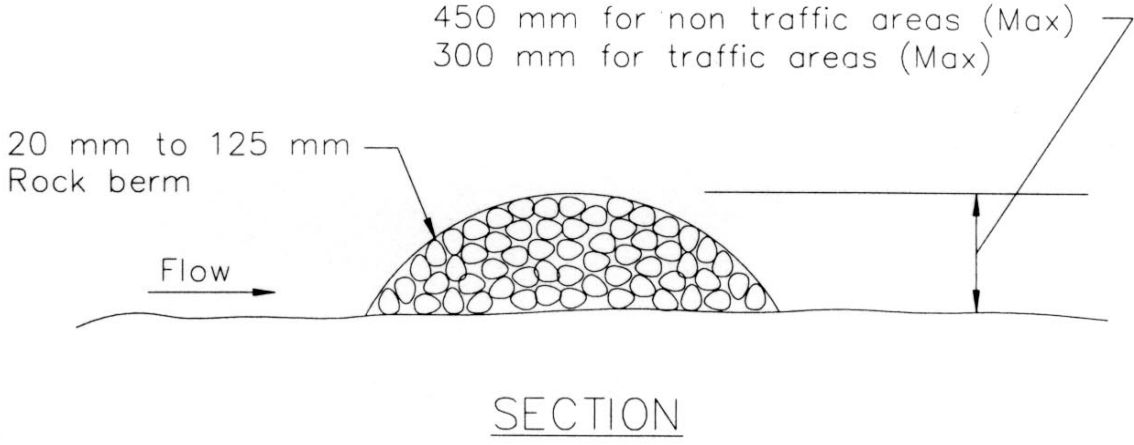

TYPICAL ROCK FILTER
NOT TO SCALE